

Table of contents

0.0	Table of contents	0.525	Building connection – press fitting, fixed-point forces
		0.530	Building connection installation
0.1	System description	0.535	Installation tool, general and for screw connection
0.100	System description (general)	0.540	Installation tool, for connection to sliding sleeves
0.105	System description (data)		
0.106	System description (data)		
0.110	Long-term behaviour/service life calculation		
0.115	FLEXSTAR UNO range, heating, 6 bar		
0.116	FLEXSTAR DUO range, heating, 6 bar		
0.2	Planning, project development		
0.200	FLEXSTAR pressure loss diagram, heating, 6 bar		
0.210	FLEXSTAR heat loss, heating, 6 bar		
0.3	Components		
0.315	L-shell		
0.316	Big L-shell		
0.325	I-shell		
0.326	Big I-shell		
0.330	T-shell		
0.335	Big T-shell		
0.365	Insulating material, PE foam		
	PUR foam container		
0.370	Screw connections, external thread, weld end		
0.375	Screw connection, elbow 90°		
0.380	Press fittings, thread, weld end with sliding sleeve		
0.385	Press fittings, coupling, elbow 90° with sliding sleeve		
0.390	Press T-piece, with sliding sleeve, heating, 6 bar		
0.405	End caps		
0.410	Wall sealing ring, for wall openings		
0.415	Building entry, wall opening		
0.420	Labyrinth wall sealing ring, core drillings/cement casing pipe		
0.425	Building entry, core drillings/cement casing pipe		
0.5	Civil engineering, installation		
0.500	Route		
0.505	Trench dimensions		
0.510	Pipe warning tape, laying aids		
0.515	Connection (rigid/flexible), FLEXSTAR plastic sheath pipe		
0.520	Building connection – screw connection, shaft entry		

System description

1. General

FLEXSTAR is the trademarked name for the most flexible pipe system from BRUGG Pipes, which is manufactured specially for low-temperature and heat pump applications in accordance with the current standard EN 15632-1/-2.

FLEXSTAR is ideal for use as a heat pump line and in small local heating networks.

The carrier pipes of the FLEXSTAR pipe system are made of cross-linked polyethylene PEXa and are equipped with an organic oxygen diffusion barrier (EVOH). The material was selected due to its outstanding thermal and mechanical properties. In addition, the carrier pipe features high corrosion and chemical resistance. It is also easy to process by hand and fulfils the applicable standards.

FLEXSTAR uses innovative thermal insulation based on the patented elastic polyurethane foam. This foam not only has excellent thermal insulation properties, but also perfectly encases the carrier pipes during the manufacturing process.

FLEXSTAR uses innovative thermal insulation based on the patented elastic polyurethane foam. This foam not only has excellent thermal insulation properties, but also perfectly encases the carrier pipes during the manufacturing process. The result is extremely stable adhesion and a force-locking bond that is an optimal complement to the physical properties of the PEXa carrier pipe. This means that FLEXSTAR can be installed without fear of thermal expansion.

Thanks to its exceptional bending capabilities, FLEXSTAR can be easily adapted to any house or heat pump inlet, making it easy to bypass obstacles without incurring additional costs.

FLEXSTAR solutions are available in different configurations. They can either be delivered as sets or transported to the construction site in the desired length in endless rings or on a drum. The option of longer delivery lengths in particular allows for laying without joints in the ground, which means the required pipe trench can be considerably narrower. This leads to substantial savings in civil engineering work, especially for DUO lines.

The FLEXSTAR systems are not only technically perfect, but also significantly optimize processes on the construction site thanks to their extremely short installation time. This makes them the key to creating heat pump or local heating connections that save both time and money.

Installing the connection pieces is very simple. Whether with conventional screw connections or press fittings, installation of the connections is quick and safe. Our extensive range of accessories also guarantees solutions for any conceivable situation.

Additional accessories such as wall seals with cable glands or EPDM end caps round out and complement our product range to even better cover your needs.

2. Application area

Heating, pipe series 5 (SDR 11):

Max. operating temp. T_{max} : 95 °C (fluctuating)

Max. operating pressure p: 6 bar

System description

1. Composite system

Requirements Factory-insulated, flexible pipe systems according to EN 15632-1/-2
Fire behaviour Building material class B2 (normal flammability) according to DIN 4102

2. Carrier pipe

Materials Base material: High-density polyethylene (HDPE), peroxide-crosslinked (PEXa), colour: black
Bonding agent Modified PE, heat-stabilised, colour: black
Oxygen barrier layer Ethylene vinyl alcohol (EVOH), heat-stabilised, colour: black
Requirements According to DIN 16892 / DIN 16893
Oxygen tightness According to DIN 4726, at 40 °C, oxygen tightness related to the internal pipe volume of $\leq 0.10 \text{ g} / (\text{m}^3 \times \text{d})$ according to DIN 4726
DIN 16893 pipe rows Series 5 (SDR 11)
Long-term behaviour See catalogue sheet FXS 0.110
Properties Unaffected by aggressive water, low pressure losses, very good chemical and mechanical resistance

PEXa carrier pipe	Reference temp. °C	Value	Test standard
Density	-	938 kg/m ³	DIN 53479
Thermal conductivity	20	0.38 W/mK	DIN 52612
Oxygen permeability	-	< 0.1 g/(m ³ *d)	DIN 4726, ISO 17455
Elongation	-	> 400%	DIN 53455
Linear thermal expansion coefficient	20	1.4 · 10 E-4 1/K	DIN 52328
Linear thermal expansion coefficient	100	2.0 · 10 E-4 1/K	-

3. Insulation

Materials **FLEXSTAR (heating, 6 bar)**
CFC-free, cyclopentane-blown polyurethane foam (PUR)

PUR insulation	Reference temp. °C	FLEXSTAR	Test standard
Density	-	> 50 kg/m ³	EN 253
Axial shear strength	-	≥ 90 kPa	EN 15632-2
Thermal conductivity, flexible systems	50	≤ 0.024 W/mK	EN 253 and ISO 8497
Closed-cell structure	-	≥ 88 %	EN 253
Water absorption	100	≤ 10 %	EN 15632-1

4. Protective casing

Materials Linear low-density polyethylene (LLDPE), seamlessly extruded, UV-protected
Task To protect against mechanical influences and moisture

LLDPE protective casing	Reference temp. °C	Value	Test standard
Density	-	918–922 kg/m ³	ASTM D792
Thermal conductivity	-	0.33 W/mK	DIN 52612

Long-term behaviour

Service life calculation

Safety factor	Operating temperature °C	FLEXSTAR (pipe series 5 / SDR 11) Years					
		1	5	10	25	50	100
1.5	10	17.9	14.6	14.5	14.4	14.2	14.1
1.5	20	13.2	12.9	12.8	12.7	12.6	12.5
1.5	30	11.7	11.5	11.4	11.3	11.2	11.1
1.5	40	10.4	10.2	10.1	10.0	9.9	9.8
1.5	50	9.3	9.1	9.0	8.9	8.8	8.8
1.5	60	8.3	8.1	8.0	7.9	7.9	-
1.5	70	7.4	7.3	7.2	7.1	7.0	-
1.5	80	6.6	6.5	6.4	(6.4) ^a	-	-
1.3	90	6.9	6.7	6.6	-	-	-
1.3	95	6.5	6.3	6.3	-	-	-

The values in brackets apply to verification of test times longer than one year for the 110 °C test

Long-term behaviour

The permissible operating pressures according to DIN 16892/3 and 15632-2 are based on water as a flow medium and have been designed with a safety factor:

Temperature	Safety factor	Temperature range
Operating temperature (T_{op})	1.5	≤ 80 °C
Maximum operating temperature (T_{max})	1.3	> 80 °C to ≤ 95 °C
Fault temperature (T_{mal})	1.0	> 95 °C to ≤ 110 °C
^a The specified temperature range defines the safety factors that must be applied to temperature/time profiles deviating from Table 1 and calculated in line with Appendix A.		

The values are monitored by the plastic pipe producer through long-term studies and are confirmed and tested by independent test institutes. The max. operating temperature is between 81°C and 95°C; however, a short-term overtemperature (fault temperature) of 96°C to 110°C is considered.

A typical smooth temperature distribution in the flow in the district heating systems results in an average temperature/year of approx. 66°C.

For the use of a PEX pipe system with changing operating temperatures, the operating time can be calculated using Miner's rule.

Usage examples

Operating temperature °C	Example 1 Annual operating duration h	Example 2 Annual operating duration h	Example 3 Annual operating duration h	Example 4 Annual operating duration h
50	0	0	185	0
55	0	0	160	4380
60	0	0	145	4380
65	0	535	130	0
70	0	3720	120	0
75	0	840	115	0
80	8468	3500	110	0
85	0	165	4500	0
90	258.7	0	0	0
95	33.3	0	5465	8760
Operating duration h/a	8760	8760	> 30 years	> 100 years ^a
Calculated service life	30 years + 100 h	> 50 years		

Pipe systems that comply with the EN 15632-2 standard are designed for a service life of at least 30 years as long as they are operated at the following temperature profile:

29 years at 80 °C
 + 1 year at 90 °C
 + 100 h at 95 °C

 30 years + 100 h

FLEXSTAR range

FLEXSTAR UNO (heating, 6 bar)

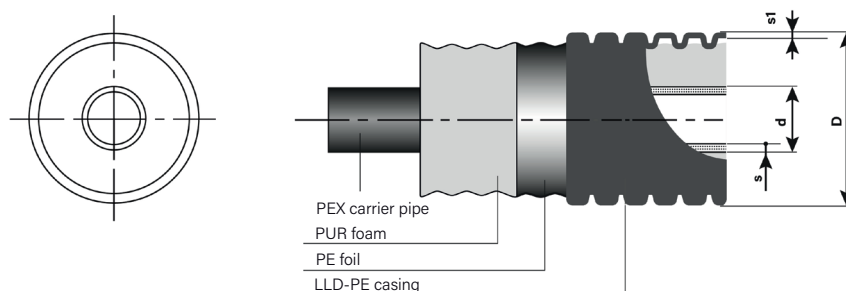

FLEXSTAR heating, 6 bar, UNO

Type	PEX inner pipe d x s	Nominal diameter		Outer casing D x s1 mm	Minimum winding radius m	Volume of inner pipe l/m	Weight kg/m	Maximum delivery length m
		DN mm	Inches "					
25/70*	25 x 2.3	20	¾	71 x 1.5	0.30	0.32	0.73	200
32/70	32 x 2.9	25	1	71 x 1.5	0.30	0.53	0.84	200
40/90	40 x 3.7	32	1¼	90 x 1.6	0.30	0.83	1.25	200
50/90	50 x 4.6	40	1½	90 x 1.6	0.30	1.30	1.44	200
63/105	63 x 5.8	50	2	106 x 1.7	0.30	2.07	2.07	200

* carrier pipe PEXc

Longer or shorter delivery lengths can be supplied on drums on request.

When ordering at the construction site, please observe the total weight of the ring (unwinding equipment)

FLEXSTAR range

FLEXSTAR DUO (heating, 6 bar)

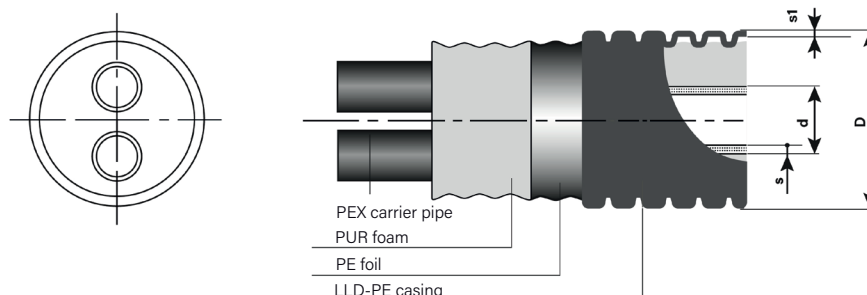

FLEXSTAR heating, 6 bar, DUO

Type	PEX inner pipe d x s mm	Nominal diameter		Outer casing D x s1 mm	Minimum winding radius m	Volume of inner pipe l/m	Weight kg/m	Maximum delivery length m
		DN	Inches					
25 + 25/ 90*	2 x 25 x 2.3	20 + 20	2 x ¾	90 x 1.6	0.30	2 x 0.32	1.16	200
32 + 32/105	2 x 32 x 2.9	25 + 25	2 x 1	106 x 1.7	0.30	2 x 0.53	1.66	200
40 + 40/125	2 x 40 x 3.7	32 + 32	2 x 1¼	126 x 1.8	0.35	2 x 0.83	2.28	200
50 + 50/150	2 x 50 x 4.6	40 + 40	2 x 1½	151 x 1.9	0.40	2 x 1.30	3.05	150

* carrier pipe PEXc

When ordering at the construction site, please observe the total weight of the ring (unwinding equipment)

Pressure loss diagram

FLEXSTAR (heating, 6 bar)

Water temperature 80 °C

Surface roughness $\epsilon = 0.007$ mm (PEX)

(1 mmWS = 9.81 Pa)

$\dot{m} \approx \frac{Q \cdot 860}{\Delta T}$	\dot{m} =	flow in kg/h
	Q =	power requirement in kW
	ΔT =	temperature difference Flow/return in °C

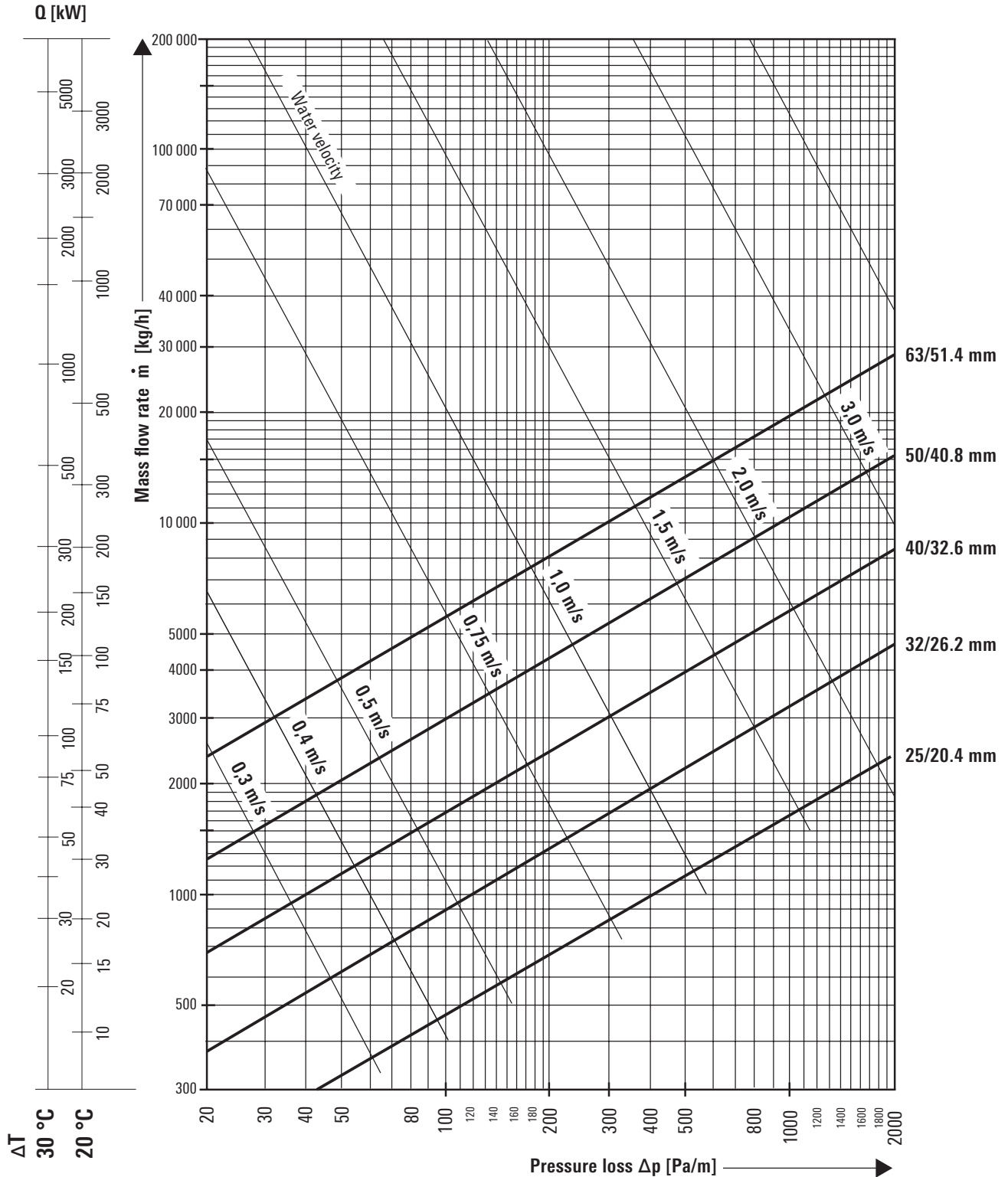

Heat loss

FLEXSTAR (heating, 6 bar)

FLEXSTAR DUO

(flow and return in one pipe)

Heat losses q [W/m] for a laid DUO pipe

Type	U value [W/mK]	Average operating temperature T _B [°C]					
		40°	50°	60°	70°	80°	90°
25 + 25/ 90	0.22	6.5	8.7	10.8	13.0	15.1	17.3
32 + 32/105	0.24	7.2	9.7	12.1	14.5	16.9	19.3
40 + 40/125	0.26	7.7	10.3	12.8	15.4	18.0	20.5
50 + 50/150	0.28	8.3	11.1	13.9	16.7	19.5	22.3

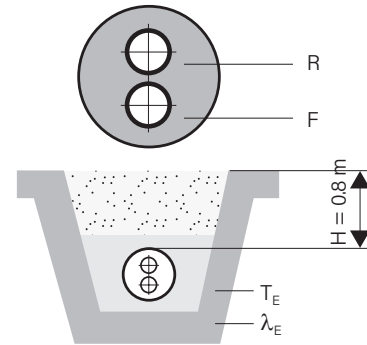

FLEXSTAR UNO

Heat losses q [W/m] for for two UNO pipes laid in pairs

Type	U value [W/mK]	Average operating temperature T _B [°C]					
		40°	50°	60°	70°	80°	90°
25/ 70	0.26	7.8	10.4	13.0	15.6	18.2	20.8
32/ 70	0.33	9.9	13.2	16.5	19.8	23.1	26.4
40/ 90	0.33	9.8	13.1	16.4	19.7	23.0	26.3
50/ 90	0.43	13.0	17.3	21.7	26.0	30.3	34.7
63/105	0.48	14.3	19.1	23.9	28.7	33.5	38.2

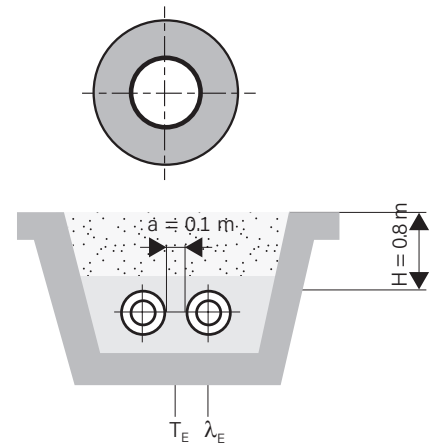

FLEXSTAR UNO

Heat losses q [W/m] for a single UNO pipe

Type	U value [W/mK]	Average operating temperature T _B [°C]					
		40°	50°	60°	70°	80°	90°
25/ 70	0.15	4.6	6.1	7.6	9.1	10.7	12.2
32/ 70	0.20	6.1	8.1	10.2	12.2	14.2	16.3
40/ 90	0.20	5.9	7.8	9.8	11.8	13.7	15.7
50/ 90	0.28	8.3	11.1	13.8	16.6	19.4	22.1
63/105	0.31	9.3	12.4	15.5	18.6	21.7	24.8

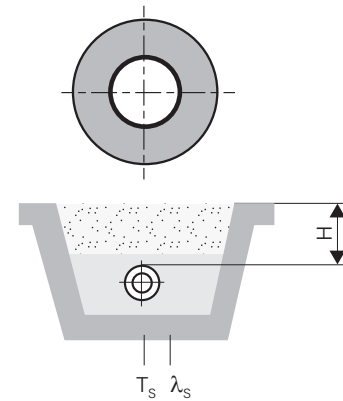

Pipe spacing: a = 0.10 m
 Cover height: H = 0.80 m
 Ground temperature: T_S = 10 °C
 Conductivity of the ground: λ_S = 1,000 $\frac{W}{mK}$
 Conductivity of the PUR foam: λ_i = 0.023 $\frac{W}{mK}$
 Conductivity of the PE casing: λ_{PE} = 0,330 $\frac{W}{mK}$

average operating temperature T_B (C°)
 Flow: F
 Return: R
 thermal transmittance coefficient U [$\frac{W}{m}$]
 Heat loss during operation: q = U (T_B-T_S) [$\frac{W}{m}$]

L-shell

Dimensions: Ø 70–125 mm

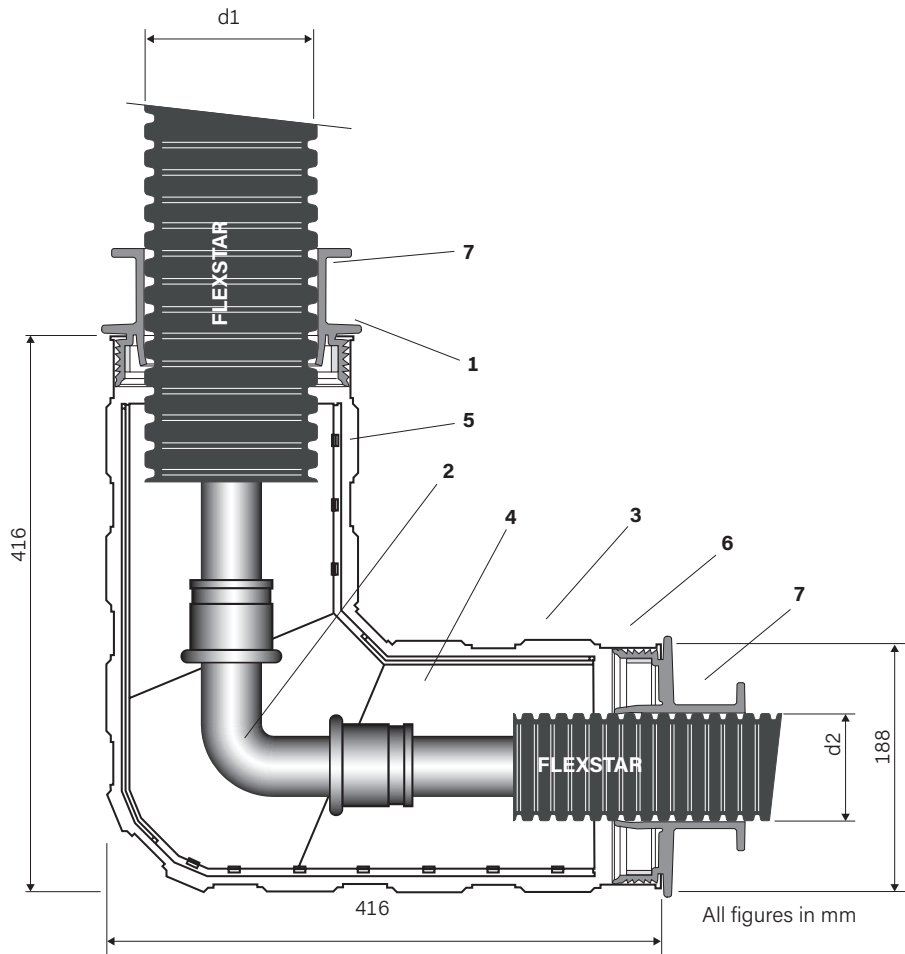

Clip-L-shell, UNO/DUO

Outer casing Ø d1	Ø d2			
	70	90	105	125
70	F			
90		C		
105			F	
125				C

F = FLEXSTAR

C = CALPEX

Structure of the half-shells

- 1 ABS half-shells
- 2 PEX angled coupling; see FXS 0.385
- 3 Locking clips (15 pcs.)
- 4 Insulating material; see FXS 0.365
- 5 Adhesive surfaces
- 6 Reducer ring or sealing ring
- 7 Hose clips

CALPEX shells must be installed so that they are protected from solar radiation if possible.

Can be combined with CALPEX sealing rings

Big L-shell

Dimensions: Ø 70–150 mm

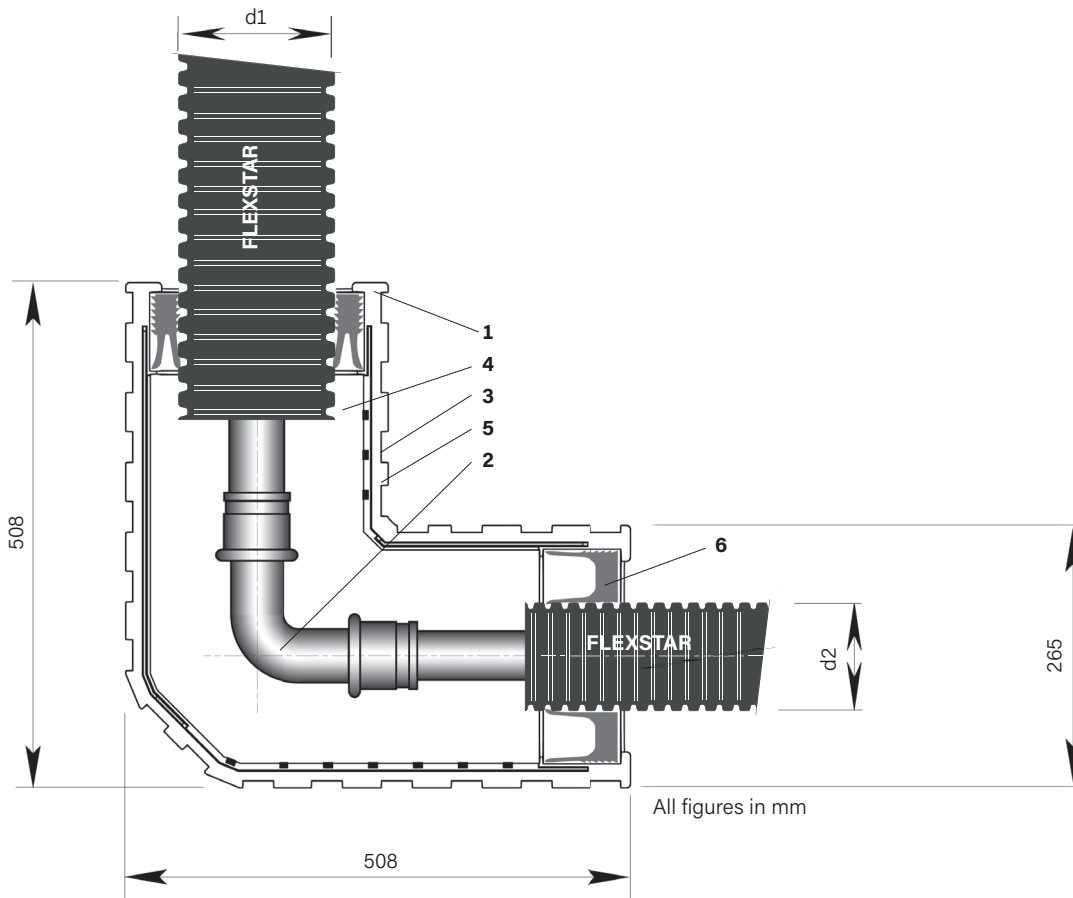

Clip-Big L-shell, UNO/DUO

Outer casing Ø d1	Ø d2				
	70	90	105	125	150
70	F				
90		F			
105			F		
125				F	
150					F

F = FLEXSTAR

Structure of the half-shells

- 1 ABS half-shells
- 2 PEX angled coupling; see FXS 0.385
- 3 Locking clips (22 pcs.)
- 4 Insulating material; see FXS 0.365
- 5 Adhesive surfaces
- 6 Reducer ring or sealing ring

CALPEX shells must be installed so that they are protected from solar radiation if possible.

I-shell

Dimensions: Ø 70–125 mm

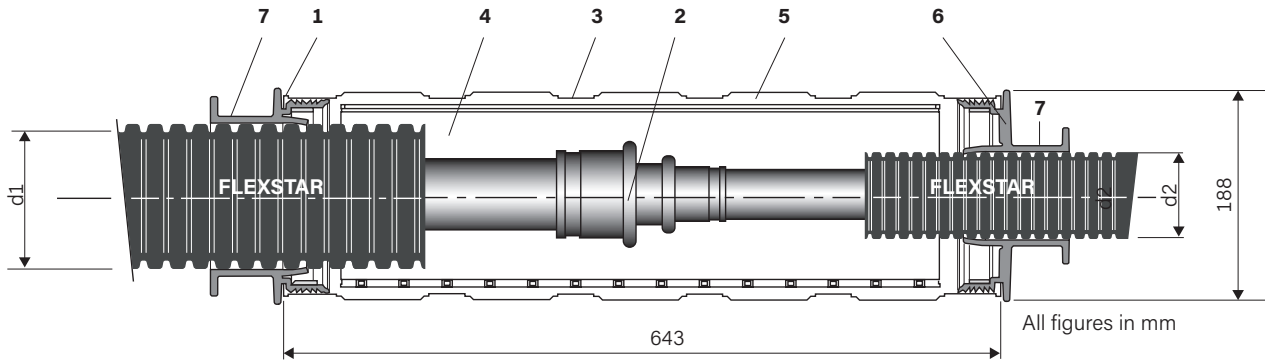

Clip-I-shell, UNO/DUO

Outer casing Ø d1	Ø d2			
	70	90	105	125
70	F			
90		C		
105			F	
125				C

F = FLEXSTAR

C = CALPEX

Structure of the half-shells

- 1 ABS half-shells
- 2 PEX angled coupling; see FXS 0.380
- 3 Locking clips (14 pcs.)
- 4 Insulating material; see FXS 0.365
- 5 Adhesive surfaces
- 6 Reducer ring or sealing ring
- 7 Hose clips

CALPEX shells must be installed so that they are protected from solar radiation if possible.

Can be combined with CALPEX sealing rings

Big I-shell

Dimensions: Ø 70–150 mm

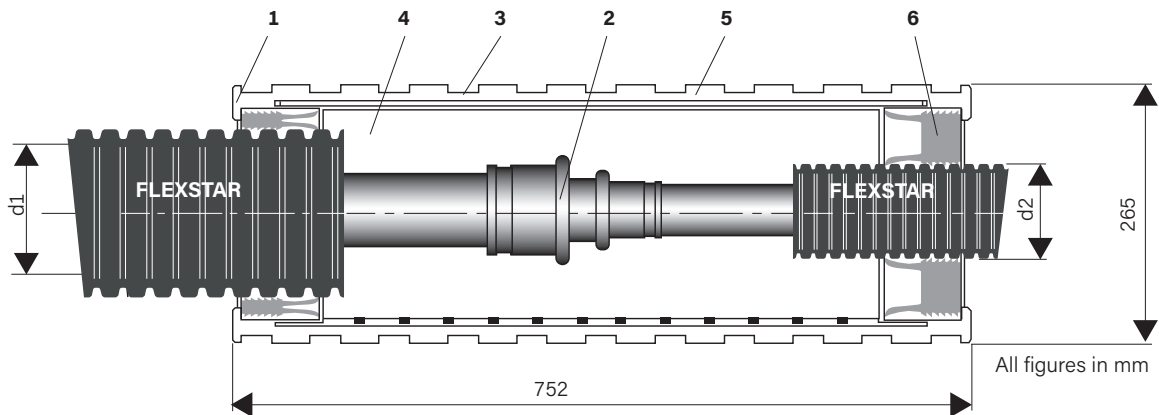

Clip-Big I-shell, UNO/DUO/QUADRIGA

Outer casing Ø d1	Ø d2				
	70	90	105	125	150
70	F				
90	F	F			
105	F	F	F		
125	F	F	F	F	
150	F	F	F	F	F

F = FLEXSTAR

Structure of the half-shells

- 1 ABS half-shells
- 2 PEX angled coupling; see FXS 0.380
- 3 Locking clips (22 pcs.)
- 4 Insulating material; see FXS 0.365
- 5 Adhesive surfaces
- 6 Reducer ring or sealing ring

CALPEX shells must be installed so that they are protected from solar radiation if possible.

T-shell

Dimensions: Ø 70–125 mm

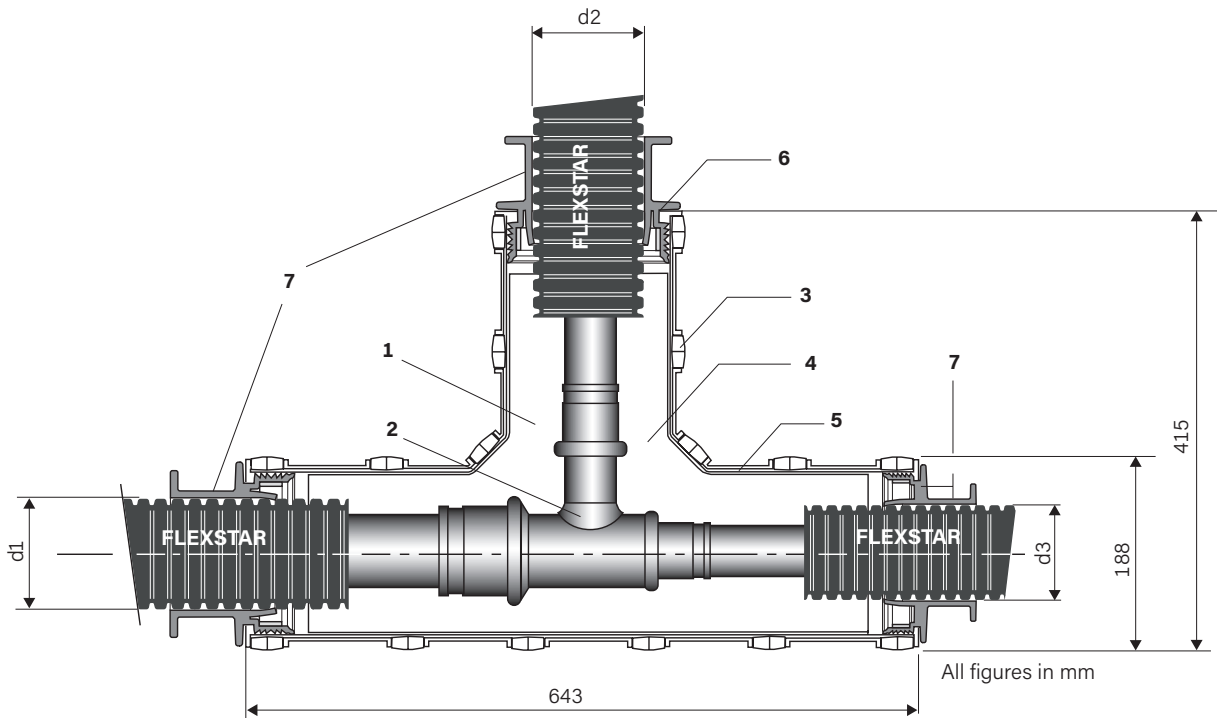

Clip-T-shell, UNO/DUO

Outer casing Ø d1-Ø d3	Branch, Ø d2			
	70	90	105	125
70	F			
90		C		
105			F	
125				C

F = FLEXSTAR

C = CALPEX

Structure of the half-shells

- 1 ABS half-shells
- 2 PEX T-piece; see FXS 0.390
- 3 Locking clips (20 pcs.)
- 4 Insulating material; see FXS 0.365
- 5 Adhesive surfaces
- 6 Reducer ring or sealing ring
- 7 Hose clips

CALPEX shells must be installed so that they are protected from solar radiation if possible.

Big T-shell

Dimensions: Ø 70–150 mm

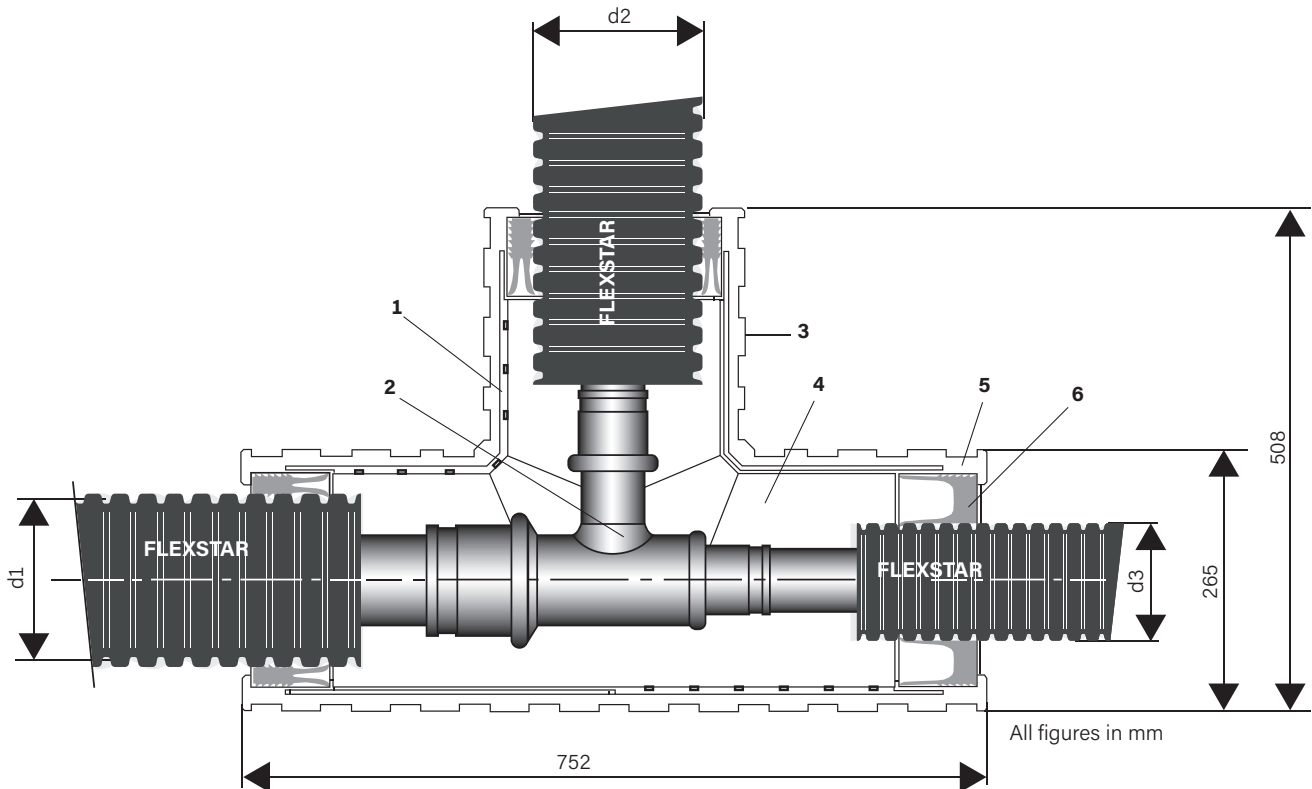

Structure of the half-shells

- 1 ABS half-shells
- 2 PEX T-piece; see FXS 0.390
- 3 Locking clips (27 pcs.)
- 4 Insulating material; see FXS 0.365
- 5 Adhesive surfaces
- 6 Reducer ring or sealing ring

Clip-Big T-shell, UNO/DUO

Outer casing Ø d1	Ø d2				
	70	90	105	125	150
70	F				
90	F	F			
105	F	F	F		
125	F	F	F	F	
150	F	F	F	F	F

F = FLEXSTAR

CALPEX shells must be installed so that they are protected from solar radiation if possible.

Insulating material

PUR foam container

Insulating material for shrink-on sleeves and the Clip-shells

PUR foam container (25/70-50 + 50/150)

CFC-free, CO₂-blown PUR foam in plastic bottles

The required amount of PUR foam (CFC-free) is supplied in the appropriate container sizes for the various sleeves and T-pieces. The components are supplied in two separate bottles and are only mixed when used. Please note the safety regulations in the installation instructions provided.



Safety regulations

For foaming, eye protection and gloves must be used.

Plastic gloves

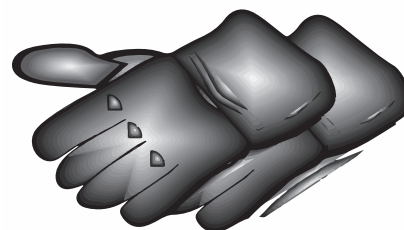

Eye protection



Screw connections

External thread, weld end

Connection with external thread

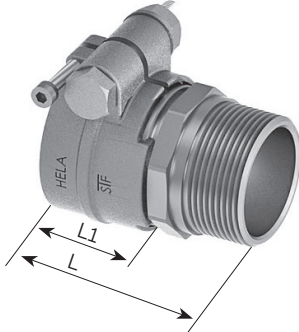

FLEXSTAR (heating, 6 bar)

Material: Brass

PEX pipe mm	Screw connection mm	L/L1 mm
25 x 2.3	25 x 2.3-3/4"	61/26
32 x 2.9	32 x 2.9-1"	68/29
40 x 3.7	40 x 3.7-1 1/4"	77/36
50 x 4.6	50 x 4.6-1 1/2"	79/36
63 x 5.7	63 x 5.7-2"	97/46

Connection with weld end

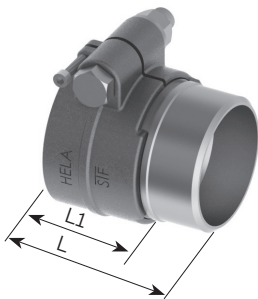

FLEXSTAR (heating, 6 bar)

Material: Steel

PEX pipe mm	Weld end mm	L/L1 mm
25 x 2.3	26.9 x 2.3	61/26
32 x 2.9	33.7 x 2.6	63/29
40 x 3.7	42.4 x 2.6	75/36
50 x 4.6	48.3 x 2.6	84/36
63 x 5.7	60.3 x 2.9	88/46

Connections with weld ends must be welded first and then crimped.

Screw connection

Coupling, any, elbow 90°

Coupling, any

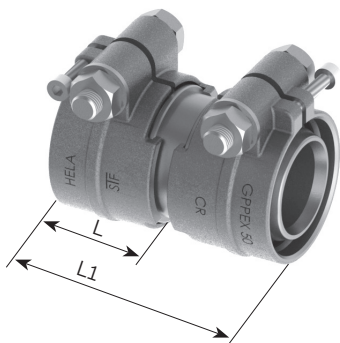

FLEXSTAR (heating, 6 bar)

Material: Brass

PEX pipe mm	Coupling mm	L/L1 mm
25 x 2.3	25 x 2.3	68/26
32 x 2.9	32 x 2.9	75/29
40 x 3.7	40 x 3.7	90/36
50 x 4.6	50 x 4.6	90/36
63 x 5.7	63 x 5.7	110/46

Reduced couplings (soldered) can be supplied on request

Elbow 90°



FLEXSTAR (heating, 6 bar)

Material: Brass, soldered

PEX pipe mm	On PEX pipe mm
25 x 2.3	25 x 2.3
32 x 2.9	32 x 2.9
40 x 3.7	40 x 3.7
50 x 4.6	50 x 4.6
63 x 5.7	63 x 5.7

Press fittings

External thread, weld end

Connection with external thread

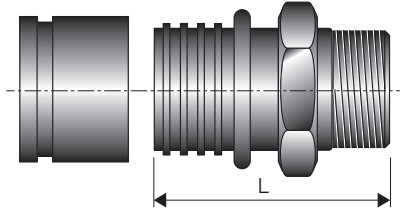

FLEXSTAR (heating, 6 bar)

Material: Brass

PEX pipe mm	Screw connection mm	L mm
25 x 2.3	25 x 2.3-3/4"	62
32 x 2.9	32 x 2.9-1"	72
40 x 3.7	40 x 3.7-1 1/4"	82
50 x 4.6	50 x 4.6-1 1/2"	89
63 x 5.8	63 x 5.7-2"	109

Connection with weld end

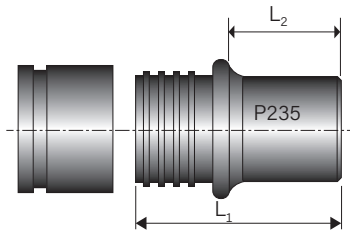

FLEXSTAR (heating, 6 bar)

Material: Steel (P235)

PEX pipe mm	Weld end mm	L1 mm	L2 mm
25 x 2.3	26.9 x 2.65	50	20
32 x 2.9	33.7 x 2.3	60	24
40 x 3.7	42.4 x 2.6	70	29
50 x 4.6	48.3 x 2.6	85	37
63 x 5.8	60.3 x 2.9	90	32

Connections with weld ends must be welded first and then crimped.

For pressing tools, see FXS 0.540

Press fittings

Coupling, any, reduced coupling, elbow 90°

Coupling

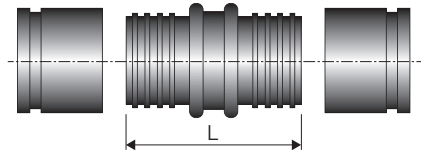

FLEXSTAR (heating, 6 bar)

Material: Brass

PEX pipe mm	Coupling mm	L mm
25 x 2.3	25 x 2.3	67.0
32 x 2.9	32 x 2.9	88.0
40 x 3.7	40 x 3.7	100.0
50 x 4.6	50 x 4.6	114.0
63 x 5.8	63 x 5.7	141.0

Coupling, reduced

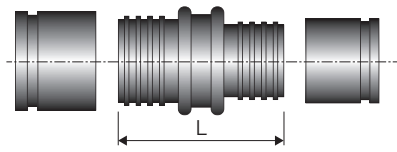

FLEXSTAR (heating, 6 bar)

Material: Brass/steel* (P235)

PEX pipe mm	Coupling mm	L mm
32 x 2.9	25 x 2.3	80.0
40 x 3.7	32 x 2.9	100.0
50 x 4.6	40 x 3.7	108.0
63 x 5.8	50 x 4.6	129.0

Elbow 90°

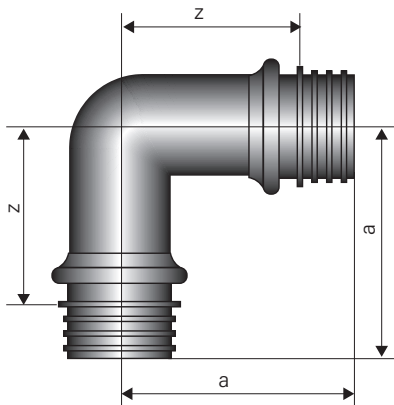

FLEXSTAR (heating, 6 bar)

Material: Brass/steel* (P235)

PEX pipe mm	PEX pipe mm	a mm	z mm
25 x 2.3	25 x 2.3	54	32
32 x 2.9	32 x 2.9	64	37
40 x 3.7	40 x 3.7	74	42
50 x 4.6	50 x 4.6	87	48
63 x 5.8	63 x 5.8	106	60

For pressing tools, see FXS 0.540

Press fittings

T-piece

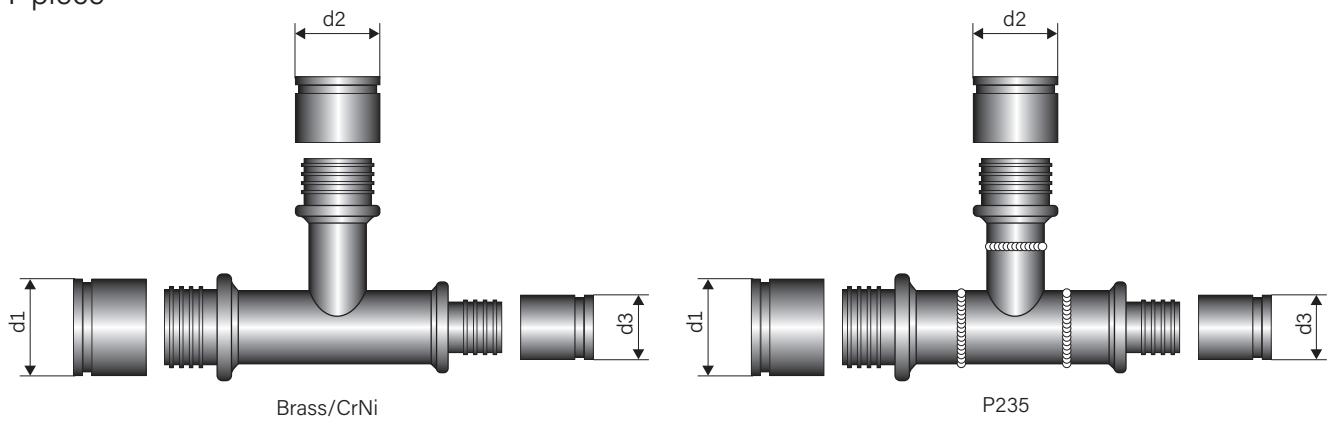

FLEXSTAR (Heating, 6 bar)

ø d1 ø d3 mm	Branch, ø d2				
	mm				
	25 x 2.3	32 x 2.9	40 x 3.7	50 x 4.6	63 x 5.8
25 x 2.3- 25 x 2.3	o/x				
32 x 2.9- 32 x 2.9	o/x	o/x			
32 x 2.9- 25 x 2.3	o/x				
40 x 3.7- 40 x 3.7	o/x	o/x	o/x		
40 x 3.7- 32 x 2.9	o/x ¹	o/x ¹			
50 x 4.6- 50 x 4.6	o/x	o/x	o/x	o/x	
50 x 4.6- 40 x 3.7	o/x	o/x	o/x ¹		
63 x 5.8- 63 x 5.8	o/x	o/x	o/x	o/x	o/x
63 x 5.8- 50 x 4.6	o/+	o/x	o/x	o/x	

¹ Soldered fittings

- T-pieces made of steel can be supplied on request
- Other T-pieces can be supplied on request.

Material:

- x = Brass CuZn39Pb3 (DN 20 - DN 50),
Gunmetal Rg7 (DN 65 - DN 100)
- o = P235 welded
- + = CrNi 1.4404, 1.4432, 1.4435 (316L)

End caps

Shrink-on end cap, UNO



End cap EPDM, UNO



End cap, UNO (LDPE)

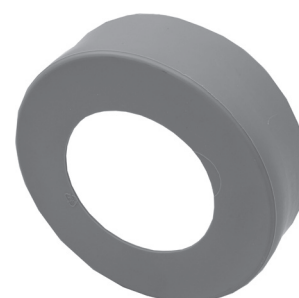

Shrink-on end cap, DUO



End cap EPDM, DUO



End cap, DUO (LDPE)

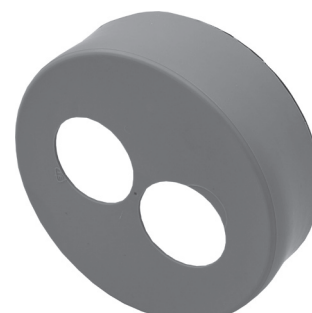

FLEXSTAR UNO

Type

25/70

32/70

40/90

50/90

63/105

FLEXSTAR DUO

Type

25 + 25/90

32 + 32/105

40 + 40/125

50 + 50/150

LD-PE end caps are attached and are suitable for dry rooms.

EPDM end caps provide optimal protection against splash water, moisture and vermin.

With exact markings for cutting the collars. Can be installed without special tools.

If a pre-insulated pipe ends in the ground, using stainless steel tightening straps provided by the customer is mandatory.

Wall sealing insert

for wall openings

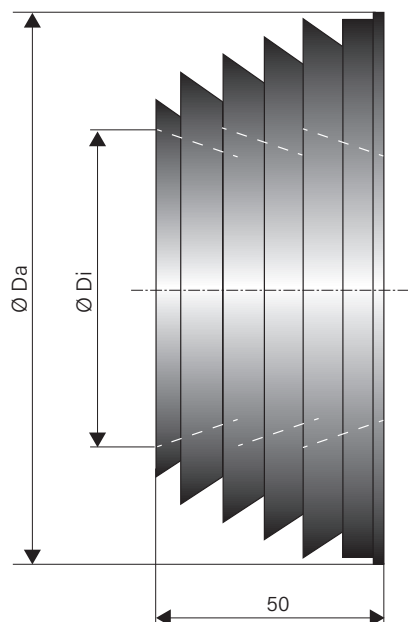

All figures in mm

FLEXSTAR UNO, DUO

Outer casing diameter	Labyrinth wall sealing ring	
mm	$\varnothing Di$, inner mm	$\varnothing Da$, outer mm
70	74	118
90	88	133
105	107	153
125	122	168
150	137	183

Building entry (see sheet FXS 0.415)

Building entry

Wall opening

Wall sealing insert

PEX connection piece:
see sheet 0.370
or sheet 0.390

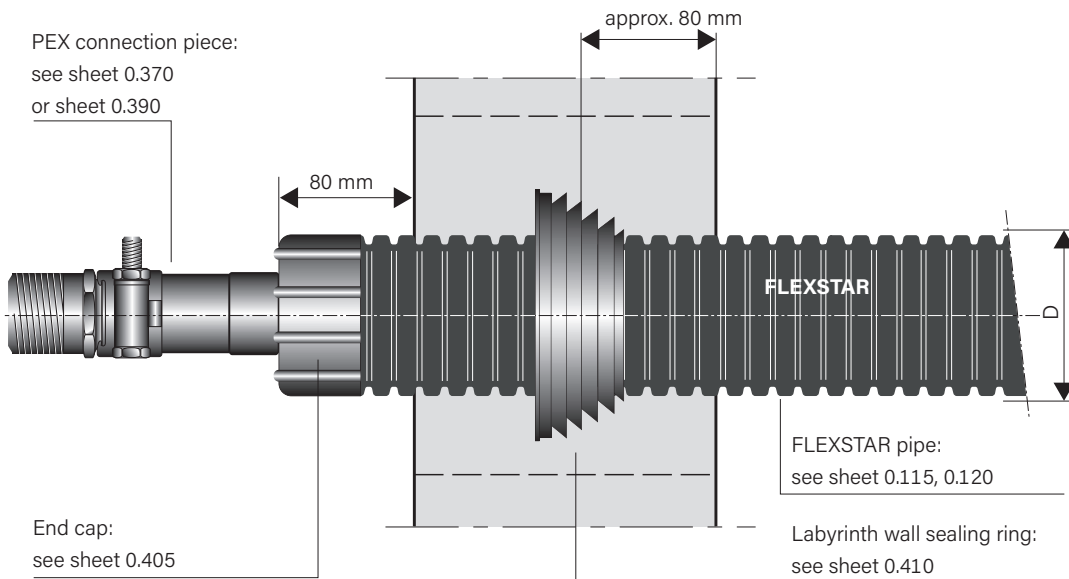

Wall opening

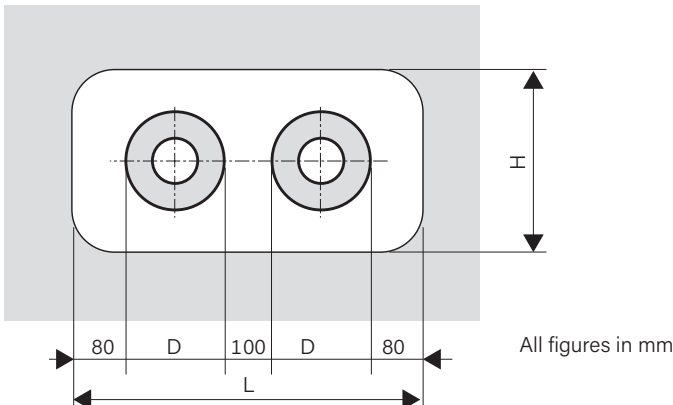

Outer casing Ø D mm	L min. mm	H min. mm
78	450	250
93	500	250
113	500	300
128	550	300
143	600	350
163	650	350
183	670	380
202	720	400
225	740	400
250	810	450

Core drillings

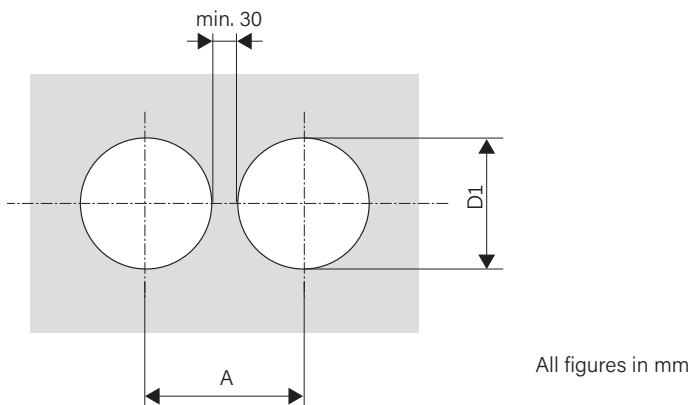

Outer casing Ø D mm	A mm	D1 mm
78	210	180
93	230	180
113	250	220
128	270	230
143	290	230
163	310	280
183	330	280
202	400	350
225	400	350
250	420	380

Wall sealing insert

Core drillings/cement casing pipes

Standard

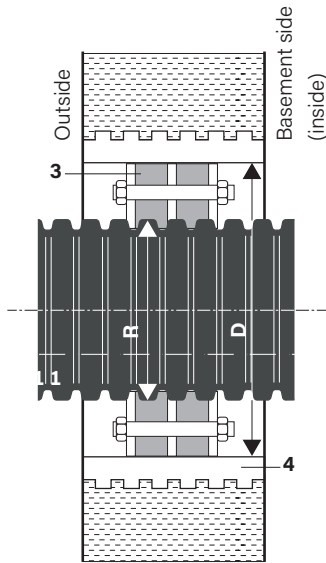

With additional centring ring

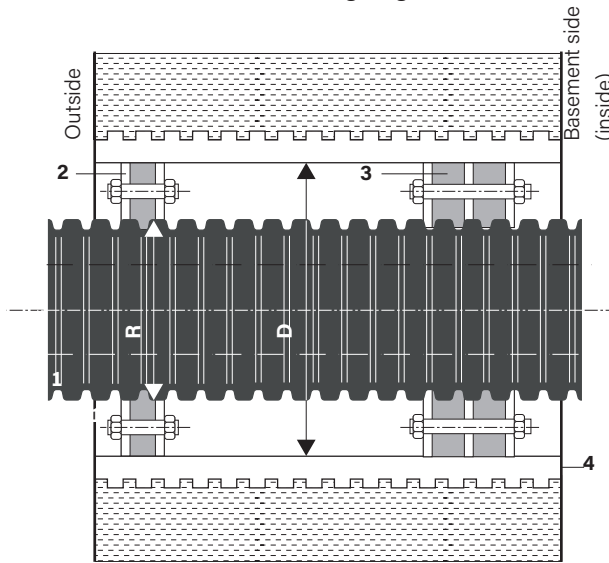

- 1 FLEXSTAR heat-pump pipe
- 2 Sealing insert, single-seal with wall thickness > 30 cm/not suitable against pressing water
1 x 40 mm, Shore hardness D 35. Also available with cable duct gland 2x Ø 32 mm.
- 3 Sealing insert, double-seal/suitable against pressing water (up to 0.5 bar)
2 x 40 mm, Shore hardness D 35. Also available with cable duct gland 2x Ø 32 mm.
- 4 Casing pipe made of fibre cement or coated core drilling

Core drillings/ Cement casing pipes

The holes must be faultless for installation. As there may be hairline cracks in the concrete or these may appear as a result of the processing work, we recommend sealing the entire wall of the drill hole with a suitable sealant (e.g. AQUAGARD).

Adhering to this recommendation is the only way to ensure leak-tightness.

Outer casing	Casing pipe	Core drilling
Ø R	Ø D	Ø
mm	mm	mm
70	150	150
90	150	200
105	200	200
125	200	200
150	250	250

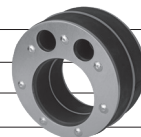

Building entry (see sheet FXS 0.425)

Building entry

Core drillings/cement casing pipes

Wall sealing insert

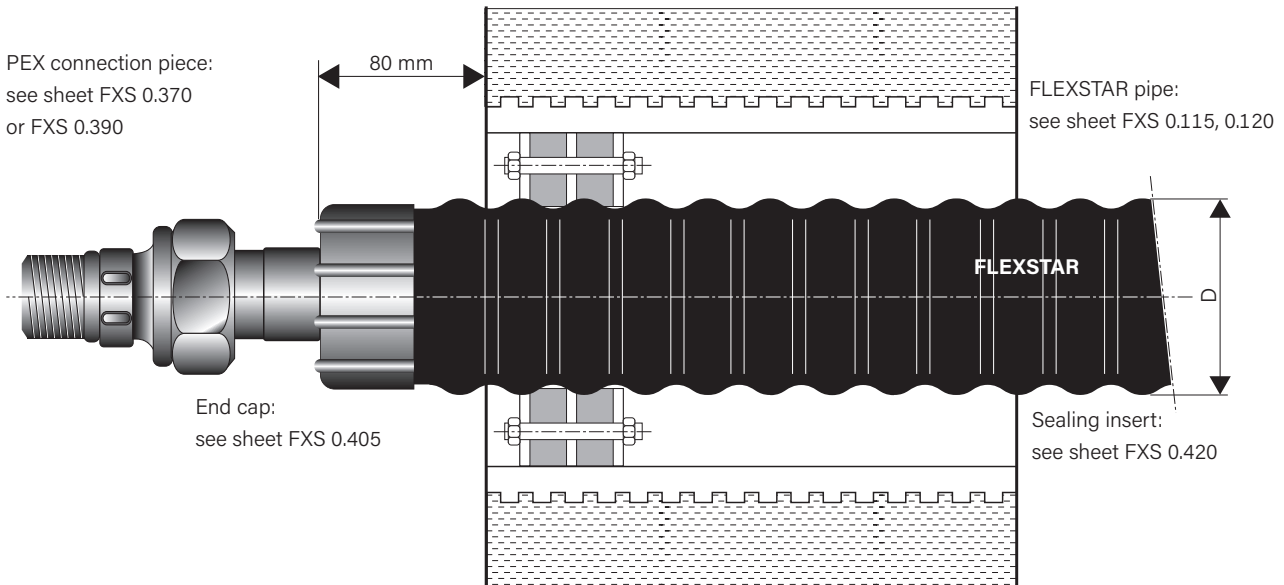

Core drillings/cement casing pipes for wall seal without cable gland 2 x Ø 32 mm

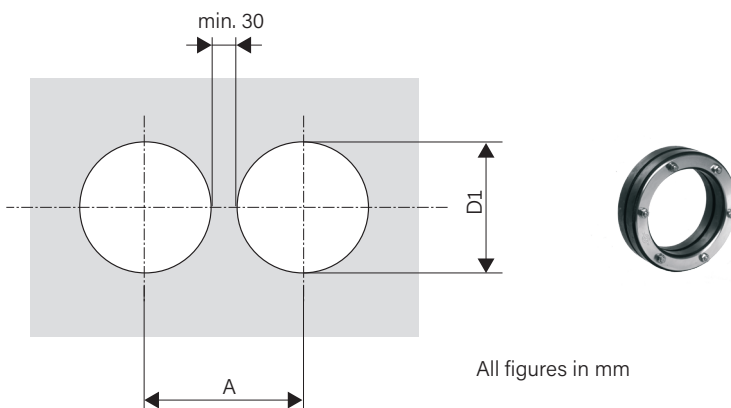

Outer casing Ø D mm	A mm	D1 mm
70	180	150
90	180	150
105	230	200
125	230	200
150	280	250

Core drillings/cement casing pipes for wall seal with cable gland 2 x Ø 32 mm

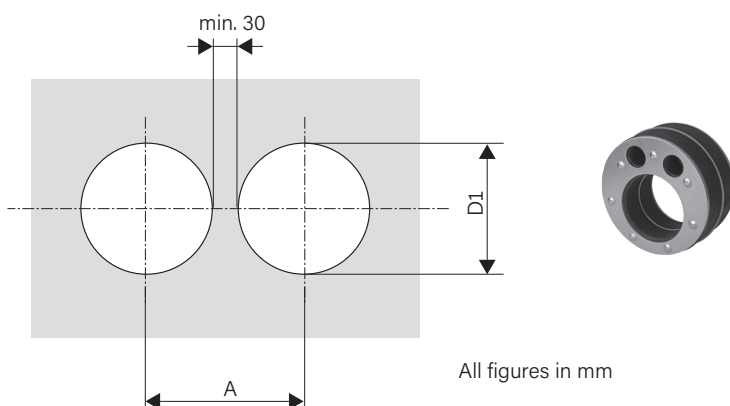

Outer casing Ø D mm	A mm	D1 mm
70	180	150
90	230	200
105	230	200
125	230	200
150	280	250

Route

Connection between FLEXSTAR and plastic sheath pipe

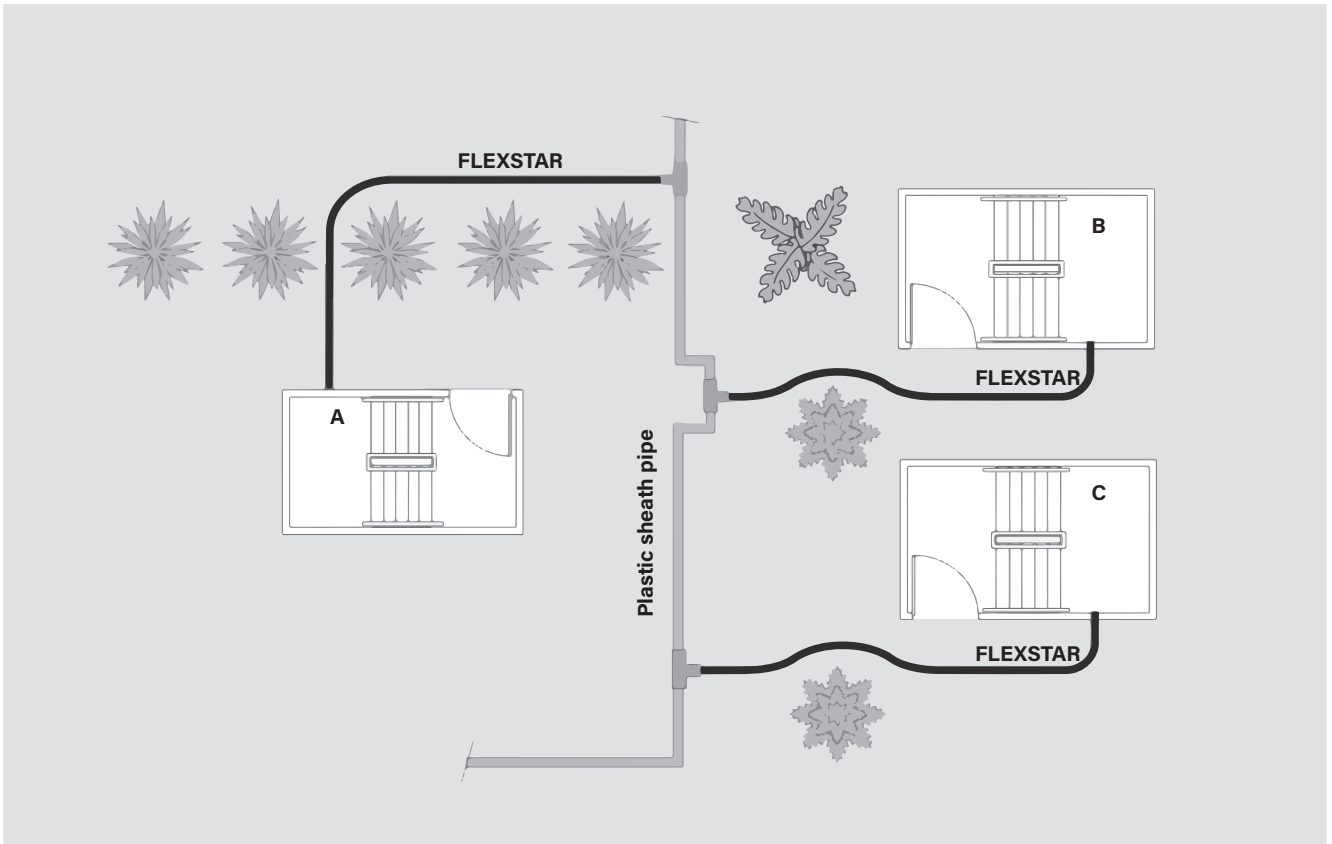

Loop-in method

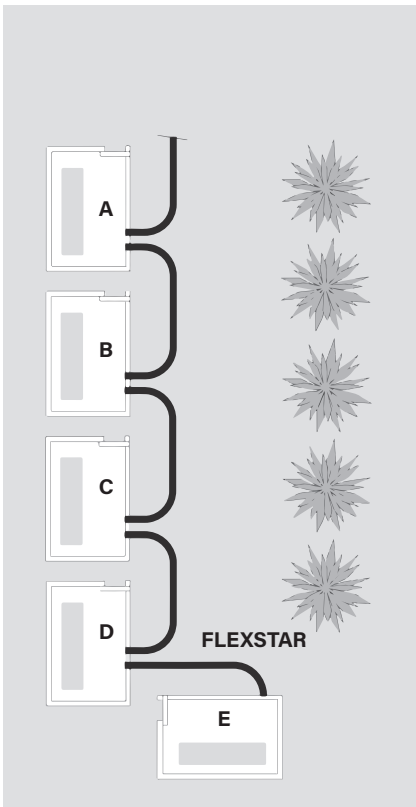

Connection between FLEXSTAR and FLEXSTAR

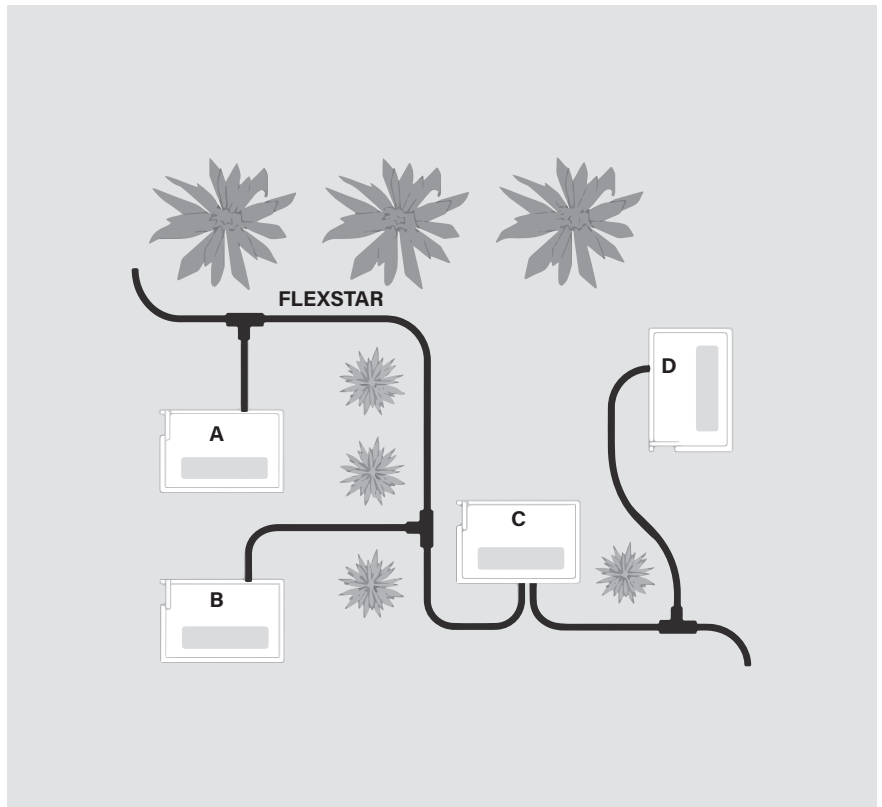

Trench dimensions

Trench profile, 2 FLEXSTAR pipes

UNO

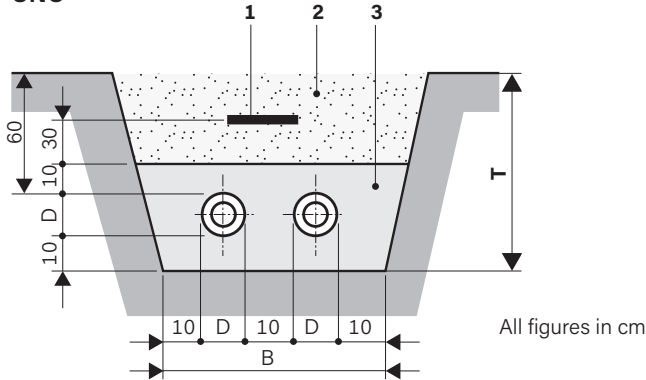

All figures in cm

Sheath pipe Ø D mm	Width B cm	Depth T cm	Minimum winding radius m
71.5	45	80	0.30
90.0	50	80	0.30
106.5	55	85	0.30
126.5	55	85	0.35
151.5	65	90	0.40

Trench profile, 4 FLEXSTAR pipes

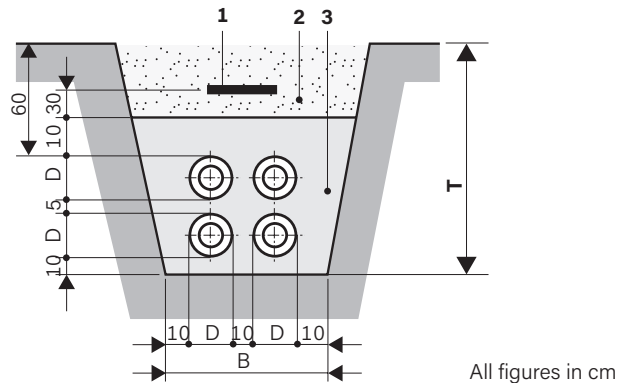
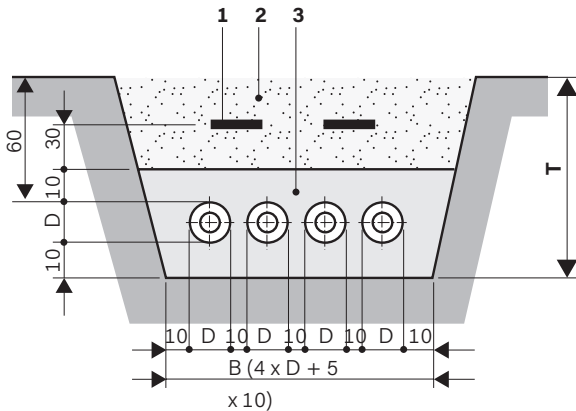

All figures in cm

- 1 Pipe warning tape; see sheet FXS 1.430
- 2 Excavated material
- 3 Fill material in line with description below

Laying depth:
Max. laying depth: 2.6 m
Our approval is required for deeper installations

SLW 30 $\hat{=}$ 300 kN total load according to DIN 1072; if subject to higher traffic loads (e.g. SLW 60), a load-distributing superstructure according to RStO75 is required.

With no traffic load, the minimum trench depth **T** can be reduced by 20 cm.

The fill material in the embedment must comply with EN 13941-2 and satisfy the following minimum requirements:

- Friable, round-edged sand-gravel mixture
- Permissible grain size: 0–8 mm
- Coefficient of uniformity according to DIN EN ISO 14688-2 greater than 1.8
- Max. 10 percent by mass \leq 0.075 mm
- Max. 3 percent by mass \leq 0.02 mm
- Proctor density min. 94 %; ideal 97–98 %

Pipe warning tape

BRUGG Pipes pipe warning tape

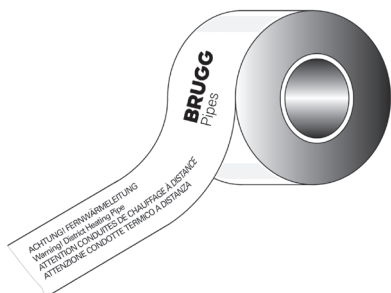

Pipe warning tape for laying in the ground.
Roll length 250 m

FLEXSTAR trench structure

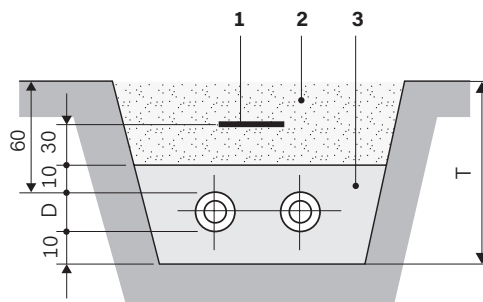

- 1 Pipe warning tape
- 2 Excavated material
- 3 Sand, washed

For the laying depth, see sheet FXS 0.505

Laying aids

With the FLEXSTAR unwinding device and a motorised winch, you can unroll pipes quickly and with minimal effort before laying them in the ground.

Unwinding device



Dimensions: Ø 400 x 157 cm
Load-bearing capacity: 1000 kg

Motorised winch



Our recommendation:
<https://www.portablewinch.com>

Squeezing tools

for shutting of PE and PEX pipe provisionally

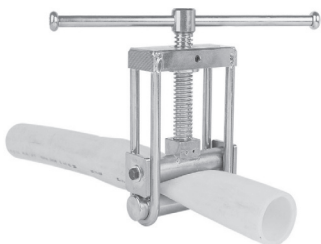

Squeezing tool Ø 32-63 mm (SDR11)

Connection (rigid/flexible)

FLEXSTAR to insulated steel pipes

Installation instructions for transition from FLEXSTAR to insulated steel pipe (KMR)

1. Connection to T-piece (Δl small)

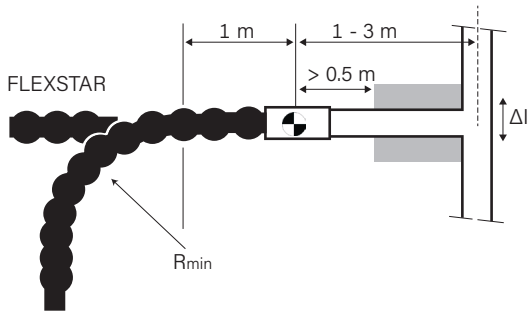

2. Connection to T-piece (Δl large)

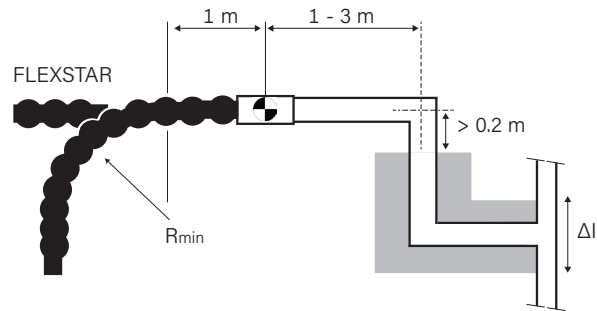

3. Connection to L-bend (Δl small)

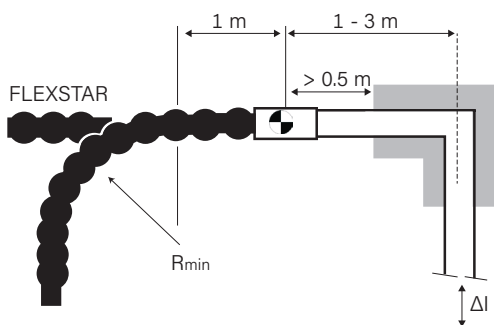

4. Connection to L-bend (Δl large)

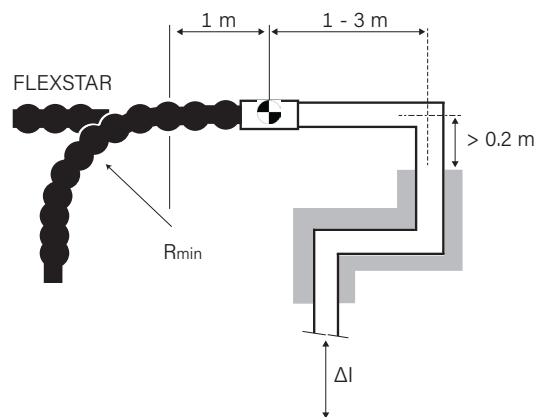

5. Connection to Z-bend

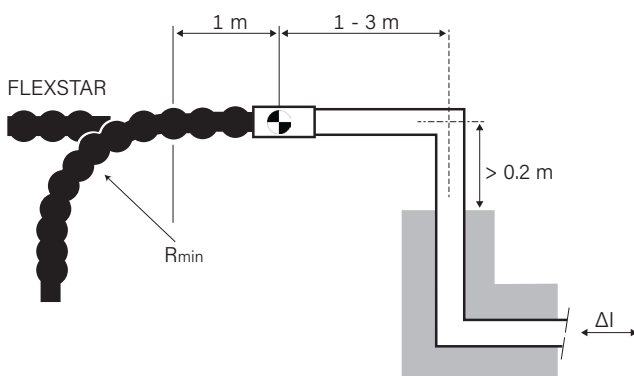

Comments:

1. Thermal elongation Δl of the KMR system that is transferred to the centre of the connector must be less than: axial 3 mm
2. Grey = expansion pad for the KMR system, designed in line with the state of the art

Building connection - screw connection/press fitting

Shaft entry

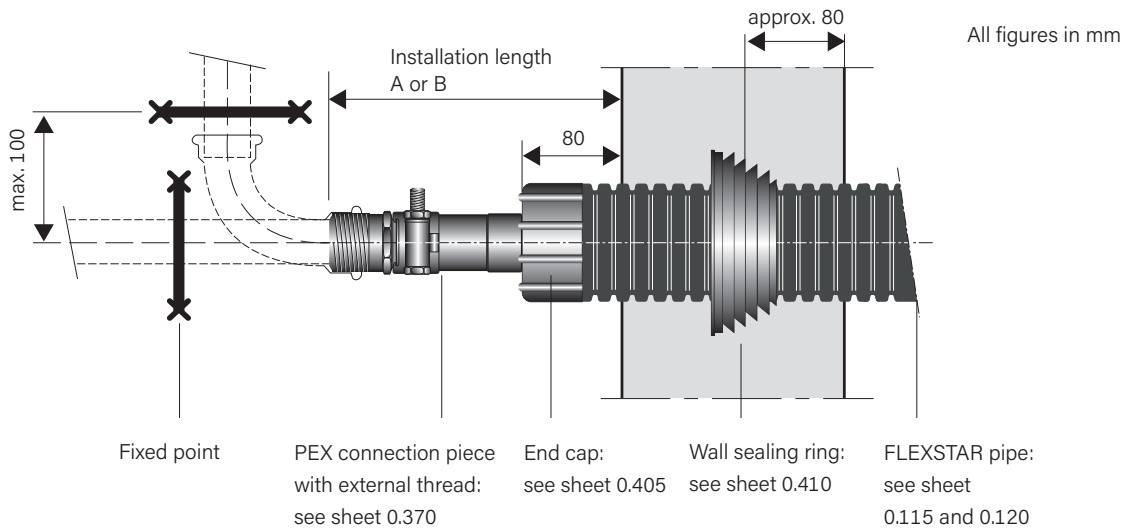

Screw connector



Press fitting

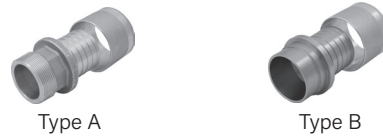

FLEXSTAR		
Heating, 6 bar	Installation lengths	
PEX pipe	A	B
mm	mm	mm
25 x 2.3	190	190
32 x 2.9	195	190
40 x 3.7	200	200
50 x 4.6	205	210
63 x 5.8	225	215

FLEXSTAR		
Heating, 6 bar	Installation lengths	
PEX pipe	A	B
mm	mm	mm
25 x 2.3	260	250
32 x 2.9	260	250
40 x 3.7	270	260
50 x 4.6	270	270
63 x 5.8	320	310

Building connection – press fitting

Fixed-point forces

Connection with external thread

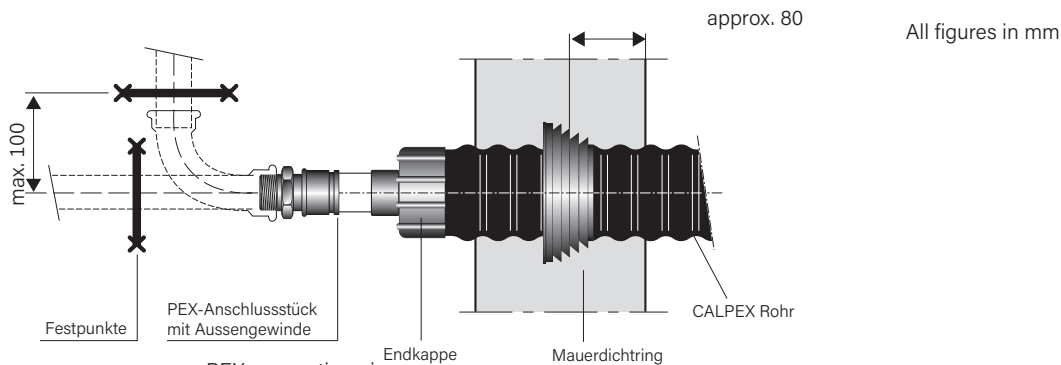

All figures in mm

Fixed point

PEX connection piece
with external thread:
see sheet 0.385

End cap:
see sheet 0.405

Wall sealing ring:
see sheet 0.410

FLEXSTAR pipe:
see sheet
0.115 and 0.120

Acting fixed-point forces FLEXSTAR (heating, 6 bar)

Maximum acting fixed-point forces **per pipe** at:

Op. temp. = 60 °C, op. pres. = 6 bar

Op. temp. = 90 °C, op. pres. = 6 bar

Type	Fmax [N]	Fmax [N]
25/ 70	640	924
32/ 70	1036	1493
40/ 90	1639	2367
50/ 90	2553	3686
63/105	4013	5782

Fixed points

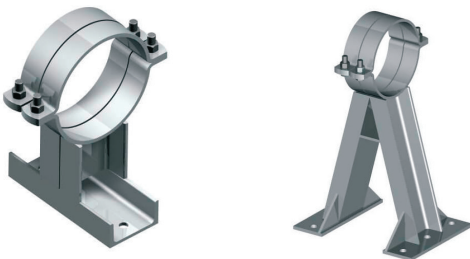

Building connection installation



1 Mark the sheath the distance (x, y, z) +1 cm from the end of the pipe.



2 Cut through the sheath with a saw.



3 Cut the sheath open lengthways. Do not insert the blade more than 5 mm deep.
Caution: Do not damage the medium pipe.



4 Peel off the sheath.



5 Cut back/remove the insulation along the length (x, y, z).
Caution: Do not damage the medium pipe.



6 Install the wall sealing ring.



7 Carefully shrink the pipe end cap in line with the enclosed Raychem DHEC installation instructions.



8 Install the fitting in line with the enclosed installation instructions.

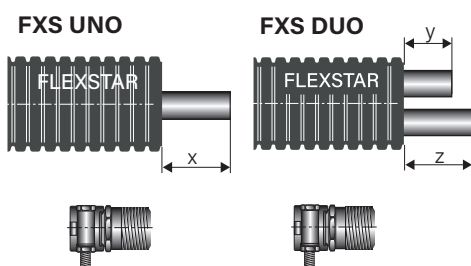

UNO screw connection

Building connection:

Ø 20- 75: X = **90 mm**

Ø 90-110: X = **110 mm**

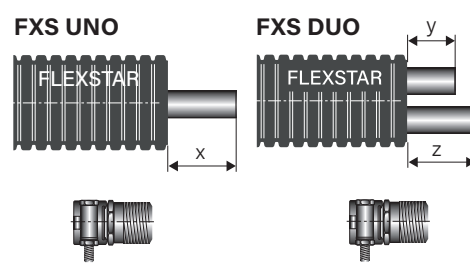

UNO press fitting

Building connection:

Ø 20- 50: X = **140 mm**

Ø 63-125: X = **180 mm**

Shrink-on sleeves:

Ø 20- 50: X = **110 mm**

Ø 63-110: X = **140 mm**

Ø 125-160: X = **150 mm**

DUO press fitting

Building connection:

Ø 20-50: Y, Z = **140 mm**

Ø 63-75: Y, Z = **160 mm**

Shrink-on sleeves:

Ø 20-50: Y, Z = **110 mm**

Ø 63-75: Y, Z = **140 mm**

Caution: Install the CPX clip shells in line with the enclosed installation instructions.

Installation tool

General and for screw connection

Cutting to length and removing insulation

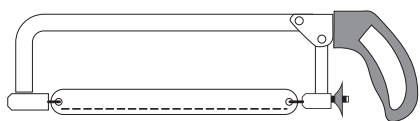

The saw is used for cutting the sheath pipe and the insulation

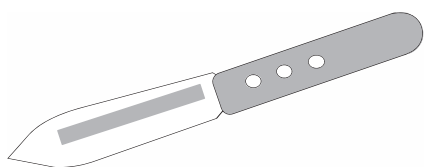

Blade for removing the insulation

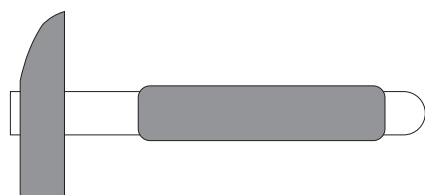

Hammer as an auxiliary tool

Cutting to length and removing insulation

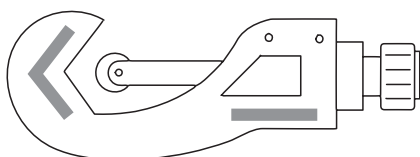

Pipe cutter for PEX pipe

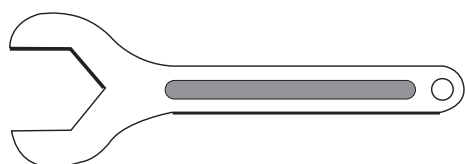

Spanner

Shrinking

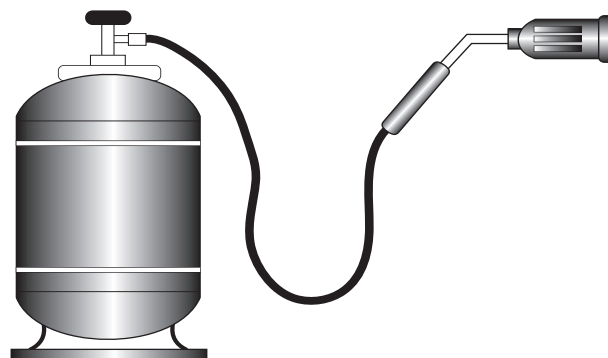

The gas burner is used to shrink hoses and sleeves



We recommend wearing gloves for shrinking work

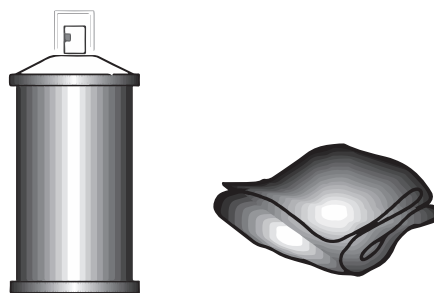

Cleaning agents and cloths

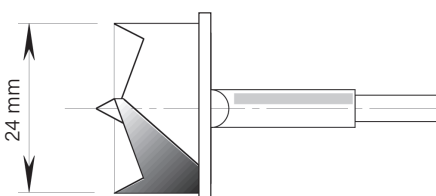

Knothole drill for foam filling hole in sleeves

Caution: Use drill with stop to avoid damage to the medium pipe.

Installation tool

For connection to sliding sleeves

Manual tool for PEX Ø 20-40 mm (1 case)

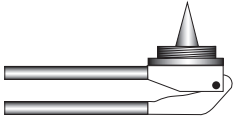

Expanding tool up to Ø 32 mm
(basic tool)

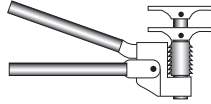

Crimping tool up to Ø 40 mm
Expanding tool for Ø 40 mm
(basic tool)



1 case with basic tool
incl. expander heads and yoke

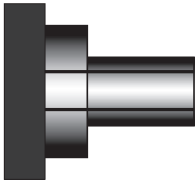

Expander head up to Ø 32 mm

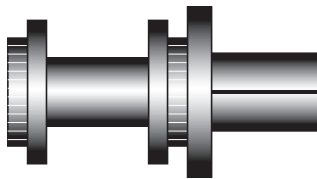

Expander head from Ø 40 mm

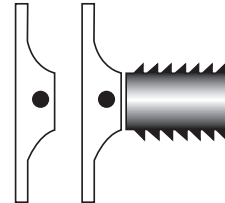

Press yoke Ø 20-40 mm

Hydraulic tool for PEX Ø 50-110 mm (2 cases)

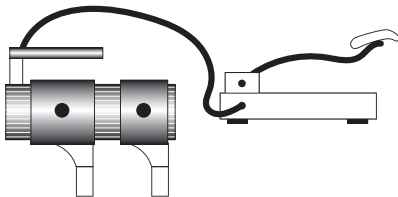

Hydraulic tool for crimping and expanding
Ø 50-110 mm including foot pump (basic tool)



Case with basic tool
(without expander heads and yoke)

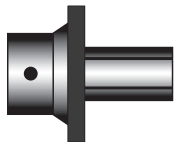

Expander head
Ø 50-110 mm

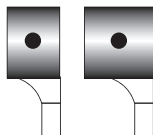

Press yoke
Ø 50, 63 mm

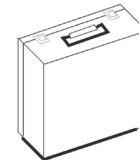

Case with expander heads
and press yoke