



Highest flexibility with efficient heat output
for heat pumps or local heating networks.



Configure now!

BRUGG
Pipes

Pioneers in Infrastructure



The innovative FLEXSTAR low-temperature system from BRUGG Pipes is a pre-insulated pipe system with maximum flexibility and stability for heat pumps or local heating networks.

Large area of application:

- Heat pumps (air/water heat pumps in particular)
- Local heating networks
 - Door-to-door connection
 - House connections
 - Renovations

BRUGG Pipes service for you

- Pipe lengths or sets including accessories precisely tailored to your needs
- Support for your planning processes
- Worldwide sales network
- Worldwide product training and support
- Production standard according to **EN 15632-2**
- Quality standard according to ISO 9001, ISO 45001 and ISO 14001



System description

FLEXSTAR UNO



FLEXSTAR DUO



Operating parameters

Operating temperature: Max. 95 °C (fluctuating)

Continuous operating temperature: Max. 80 °C

Operating pressure: 6 bar

1. Composite system

Requirements

Factory-insulated, flexible pipe systems according to EN 15632-1/-2

Fire performance

Building material class B2 (normal flammability) according to DIN 4102

2. Carrier pipe

Materials

Base material: High-density polyethylene (HDPE), peroxide-crosslinked (PEXa), colour: black

Bonding agent

Modified PE, heat-stabilised, colour: black

Oxygen barrier layer

Ethylene vinyl alcohol (EVOH), heat-stabilised, colour: black

Requirements

According to DIN 16892 / DIN 16893

Oxygen tightness

According to DIN 4726, at 40 °C, oxygen permeability related to the internal pipe volume of $\leq 0.10 \text{ g}/(\text{m}^3 \cdot \text{d})$ according to DIN 4726

DIN 16893 pipe rows

Series 5 (SDR 11)

Long-term behaviour

See catalogue sheet FXS 0.110

Properties

Unaffected by aggressive water, low pressure losses, very good chemical and mechanical resistance

PEXa carrier pipe	Reference temp. °C	Value	Test standard
Density	-	938 kg/m ³	DIN 53479
Thermal conductivity	20 °C	0.38 W/mK	DIN 52612
Oxygen permeability	-	< 0.1 g/(m ³ *d)	DIN 4726, ISO 17455
Expansion	-	> 400%	DIN 53455
Linear thermal expansion coefficient	20	1.4 · 10 ⁻⁴ 1/K	DIN 52328
Linear thermal expansion coefficient	100	2.0 · 10 ⁻⁴ 1/K	-

3. Insulation

Materials

CFC-free, cyclopentane-blown polyurethane foam (PUR)

PUR insulation	Reference temp. °C	Value	Test standard
Density	-	> 50 kg/m ³	EN 253
Axial shear strength	-	≥ 90 kPa	EN 15632-2
Thermal conductivity, flexible systems	50	≤ 0.024 W/mK	EN 253 and ISO 8497
Closed-cell structure	-	≥ 88 %	EN 253
Water absorption	100	≤ 10 %	EN 15632-1

4. Protective casing

Materials

Linear low-density polyethylene (LLDPE), seamlessly extruded, UV-protected
To protect against mechanical influences and moisture

LLDPE protective casing	Reference temp. °C	Value	Test standard
Density	-	918 - 922 kg/m ³	ASTM D792
Thermal conductivity	-	0.33 W/mK	DIN 52612

Pressure loss diagram

FLEXSTAR (heating, 6 bar)

Water temperature 80 °C
 Surface roughness $\epsilon = 0.007$ mm (PEX)
 (1 mmWS = 9.81 Pa)

$$\dot{m} \approx \frac{Q \cdot 860}{\Delta T}$$

\dot{m} = flow in kg/h
 Q = power requirement in kW
 ΔT = temperature difference
 Flow/return in °C

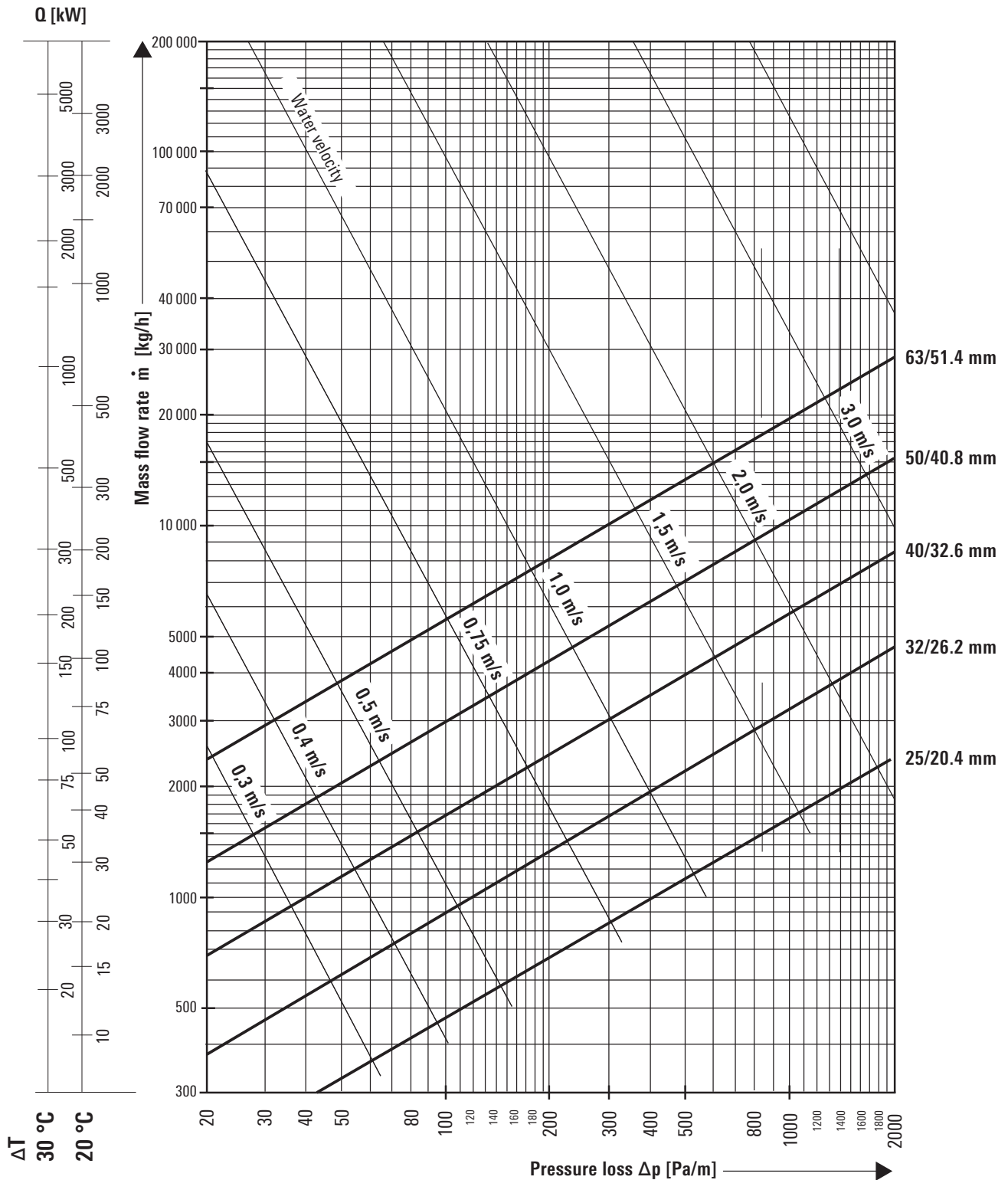

Heat loss

FLEXSTAR (heating, 6 bar)

FLEXSTAR DUO (flow and return in one pipe)

Heat loss q [W/m] for an installed DUO pipe

Type	U value [W/mK]	Average operating temperature T_B [°C]					
		40°	50°	60°	70°	80°	90°
25 + 25/ 90	0.22	6.5	8.7	10.8	13.0	15.1	17.3
32 + 32/105	0.24	7.2	9.7	12.1	14.5	16.9	19.3
40 + 40/125	0.26	7.7	10.3	12.8	15.4	18.0	20.5
50 + 50/150	0.28	8.3	11.1	13.9	16.7	19.5	22.3

Affects Switzerland:

Heat loss in accordance with EN 15632 - 1:2022 for installation of two double pipes.

The cantonal regulations in Switzerland specify the U value (U_r) per metre of installed carrier pipe.

The U value listed above can be used to calculate the heat loss per metre of installed pipe route. To be able to compare these U values with the cantonal regulations, the U-value stated here must be halved.

FLEXSTAR UNO

Heat losses q [W/m] for two pairs of installed UNO pipes

Type	U value [W/mK]	Average operating temperature T_B [°C]					
		40°	50°	60°	70°	80°	90°
25/ 70	0.26	7.8	10.4	13.0	15.6	18.2	20.8
32/ 70	0.33	9.9	13.2	16.5	19.8	23.1	26.4
40/ 90	0.33	9.8	13.1	16.4	19.7	23.0	26.3
50/ 90	0.43	13.0	17.3	21.7	26.0	30.3	34.7
63/105	0.48	14.3	19.1	23.9	28.7	33.5	38.2

Affects Switzerland:

Heat loss in accordance with EN 15632 - 1:2022 for installation of two single pipes.

The cantonal regulations in Switzerland specify the U value (U_r) per metre of installed carrier pipe.

The U value listed above can be used to calculate the heat loss per metre of installed pipe route. To be able to compare these U values with the cantonal regulations, the U-value stated here must be halved.

FLEXSTAR UNO

Heat loss q [W/m] for a single installed UNO pipe

Type	U value [W/mK]	Average operating temperature T_B [°C]					
		40°	50°	60°	70°	80°	90°
25/ 70	0.15	4.6	6.1	7.6	9.1	10.7	12.2
32/ 70	0.20	6.1	8.1	10.2	12.2	14.2	16.3
40/ 90	0.20	5.9	7.8	9.8	11.8	13.7	15.7
50/ 90	0.28	8.3	11.1	13.8	16.6	19.4	22.1
63/105	0.31	9.3	12.4	15.5	18.6	21.7	24.8

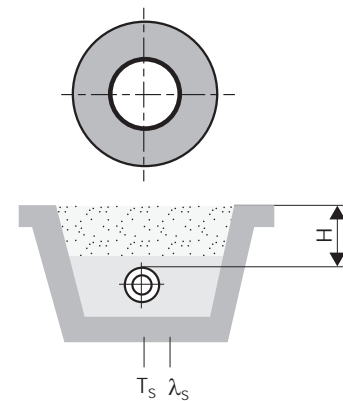
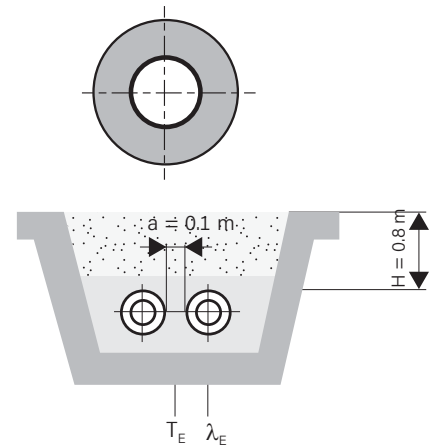
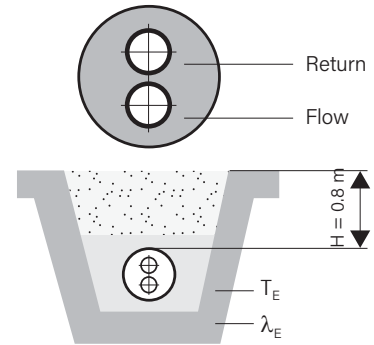

Pipe spacing: $a = 0.10$ m

Cover height: $H = 0.80$ m

Average ground temperature: $T_S = 10$ °C

at 50°C average temperature

Thermal conductivity of ground: $\lambda_s = 1.000$ $\frac{W}{mK}$

Thermal conductivity of insulation: $\lambda_i = 0.023$ $\frac{W}{mK}$

Thermal conductivity of the PE casing: $\lambda_p = 0.330$ $\frac{W}{mK}$

Average operating temperature: T_B (C°)

Flow: Flow (C°)

Return: Return (C°)

Thermal transmittance coefficient: U [$\frac{W}{mK}$]

Heat loss during operation: $q = U (T_B - T_S)$ [$\frac{W}{mK}$]

Heating range

FLEXSTAR - the flexible pipe for connecting your heat pump and local heating networks

Operating temperature:	Max. 95°C
Operating pressure:	6 bar
Carrier pipe:	Cross-linked polyethylene PEXa with oxygen diffusion barrier (EVOH)
Insulation:	Flexible hard polyurethane foam (PUR)
Outer casing:	Sturdy and UV-resistant corrugated outer casing (LLD-PE)



FLEXSTAR UNO

Type	Nominal diameter		Min. Bending radius for laying m	Bending radius acc. to EN 15132-1/-2 m	Weight kg/m	Art.-No.	Max. delivery lengths m
	DN	inch					
25/ 70	20	¾	0.30	0.85	0.73	1098219	500
32/ 70	25	1	0.30	0.90	0.84	1091668	500
40/ 90	32	1¼	0.30	1.00	1.25	1091669	500
50/ 90	40	1½	0.30	1.05	1.44	1091670	500
63/105	50	2	0.30	1.20	2.07	1091671	500



FLEXSTAR DUO

Type	Nominal diameter		Min. Bending radius for laying m	Bending radius acc. to EN 15132-1/-2 m	Weight kg/m	Art.-No.	Max. delivery lengths m
	DN	inch					
25+25/ 90	20+20	2x¾	0.30	1.00	1.16	1098220	500
32+32/105	25+25	2x1	0.30	1.15	1.66	1091674	500
40+40/125	32+32	2x1¼	0.35	1.30	2.28	1091675	350
50+50/150	40+40	2x1½	0.40	1.50	3.05	1091677	200

End caps

EPDM end caps

EPDM end caps for dry and damp spaces

As connection for building infeeds, made of EPDM.

Can also be used in the ground with stainless steel tightening straps provided by the customer.

EPDM end cap UNO

All figures in mm	Article no.
25/ 70, 32/70	4000959
40/ 90, 50/90	4001120
63/105	4001121

EPDM end cap DUO

All figures in mm	Article no.
25 + 25/ 90	4001127
32 + 32/105	4001128
40 + 40/125	4001130
50 + 50/150	4001131

Shrink-on end caps for moist areas

Heat shrinking, as connection for building infeeds, made of:

Molecular cross-linking and modified polyolefin, coated at up to 125 °C

Temperature-resistant sealing adhesive Including temperature measuring strips and abrasive strip.

UNO shrink-on end cap

All figures in mm	Article no.
25/ 70	1010754
32/ 70	1010715
40/ 90	1010715
50/ 90	1000652
63/105	1013508

DUO shrink-on end cap

All figures in mm	Article no.
25 + 25/ 90	1010755
32 + 32/105	1010679
40 + 40/125	1010679
50 + 50/150	1010939



Sealing rings

Wall seal

With cable glands 2x 32 mm for core drillings and cement casing pipes (pressing water < 0.5 bar)



All figures in mm	Article no.
Outer ø 70	4000727
Outer ø 90	4000728
Outer ø 105	4000729
Outer ø 125	4000730
Outer ø 150	4000731
Aquagard set (primer)	1010680

Wall seal

For core drillings and cement casing pipes (pressing water < 0.5 bar)



All figures in mm	Article no.
Outer ø 70	1083466
Outer ø 90	1011069
Outer ø 105	1011070
Outer ø 125	1011071
Outer ø 150	1011083
Aquagard set (primer)	1010680

Wall seal

Consisting of a specially profiled neoprene ring



All figures in mm	Article no.
Outer ø 70	1011597
Outer ø 90	1011598
Outer ø 105	1011599
Outer ø 125	1011600
Outer ø 150	1011602

Screw connections

Connection piece with external thread, screw connection (SDR 11/6 bar)

Made of brass for connection to continuing pipes

PEX pipe in mm	External thread in inches	Article no.
25 x 2.3	¾	1079134
32 x 2.9	1	1062794
40 x 3.7	1 ¼	1062795
50 x 4.6	1 ½	1069237
63 x 5.7	2	1062796



Connection piece with weld end, screw connection (SDR 11/6 bar)

Made of steel for connection to steel pipes

PEX pipe in mm	Weld end in inches	Article no.
25 x 2.3	26.9 x 2.3	1079144
32 x 2.9	33.7 x 2.6	1079145
40 x 3.7	42.4 x 2.6	1079146
50 x 4.6	48.3 x 2.6	1079147
63 x 5.7	60.3 x 2.9	1079148



Connections with weld ends must be welded first and then crimped.

Elbow 90°, any (SDR 11/6 bar)

Made of brass for connecting two district heating pipes

PEX pipe in mm	On PEX pipe in mm	Article no.
25 x 2.3	25 x 2.3	1079173
32 x 2.9	32 x 2.9	1079174
40 x 3.7	40 x 3.7	1079175
50 x 4.6	50 x 4.6	1079176
63 x 5.7	63 x 5.7	1079177



Press fittings

Connection piece with external thread, press fitting (SDR 11/6 bar)

Made of brass for connection to continuing pipes



PEX pipe in mm	External thread in inches	Article no.
25 x 2.3	¾	1011518
32 x 2.9	1	1011519
40 x 3.7	1 ¼	1011520
50 x 4.6	1 ½	1011521
63 x 5.7	2	1011522

Connection piece with weld end, press fitting (SDR 11/6 bar)

Made of steel for connection to steel pipes



PEX pipe in mm	Weld end in inches	Article no.
25 x 2.3	26.9 x 2.65	1011534
32 x 2.9	33.7 x 2.3	1011536
40 x 3.7	42.4 x 2.6	1011538
50 x 4.6	48.3 x 2.6	1011540
63 x 5.7	60.3 x 2.9	1011542

Elbow 90°, any (SDR 11/6 bar)

Made of brass for connecting two district heating pipes





PEX pipe in mm	On PEX pipe in mm	Article no.
25 x 2.3	25 x 2.3	1000779
32 x 2.9	32 x 2.9	1000780
40 x 3.7	40 x 3.7	1004928
50 x 4.6	50 x 4.6	1004924
63 x 5.7	63 x 5.7	1007624

Building entry

Wall duct / Core drilling for wall seal (compressible)

The core drillings must be faultless for installation. As there may be hairline cracks in the concrete or these may appear as a result of the processing work, we recommend sealing the drill hole drift with a suitable sealant (e.g. AQUAGARD).

Adhering to this recommendation is the only way to ensure leak-tightness.

Outer casing Ø R mm	Core drilling / Casing pipe For wall seal mm		Core drilling / Casing pipe For wall seal with cable gland 2 x Ø 32 mm	
70	150		150	
90	150		200	
105	200		200	
125	200		200	
150	250		250	

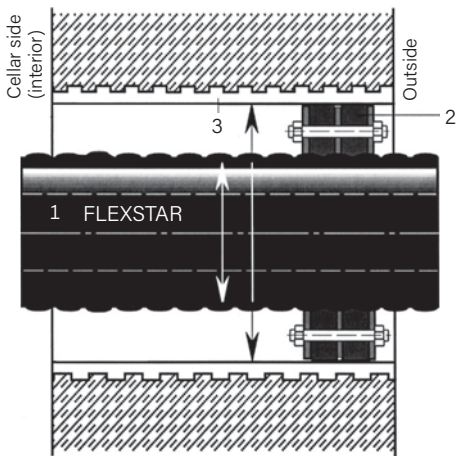

- 1 FLEXSTAR pipe
- 2 Seal set, double-sealing,
width 2 x 40 mm, shore hardness 40
- 3 Casing pipe made of fibre cement or coated
core drilling

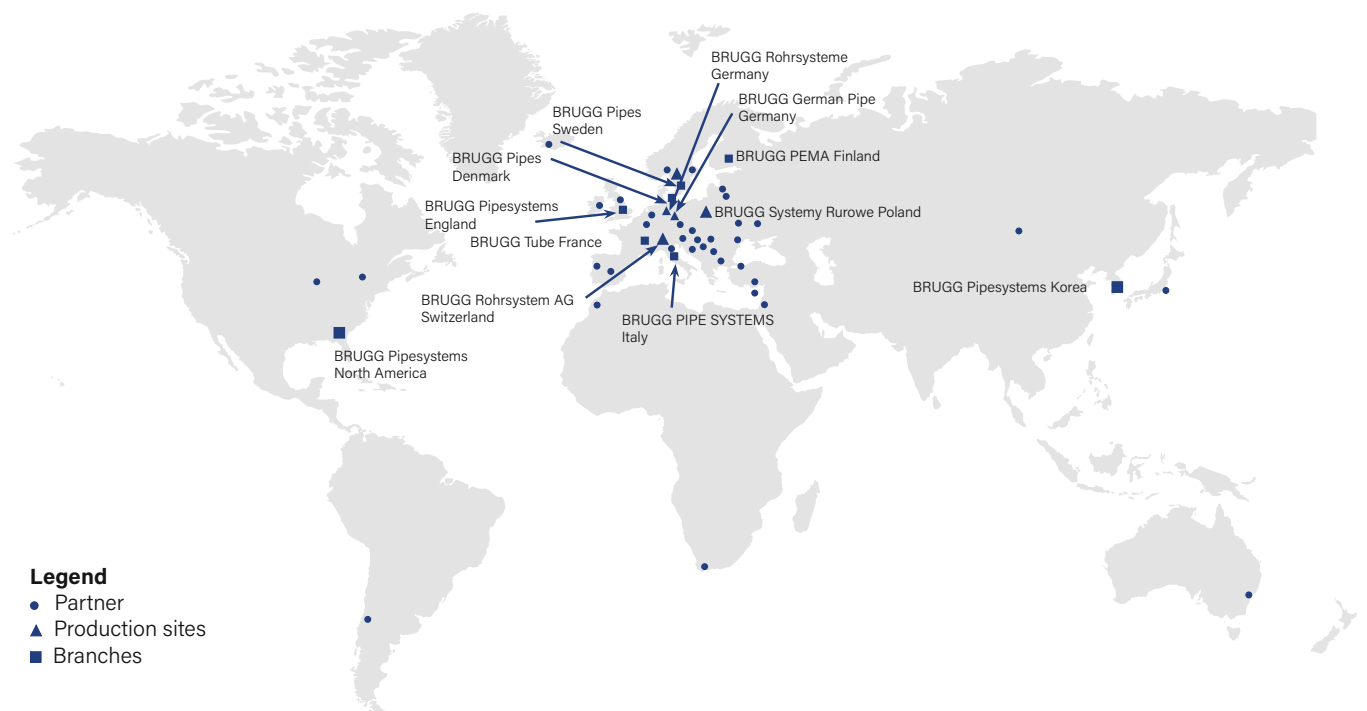

- Legend**
- Partner
 - ▲ Production sites
 - Branches



BRUGG

Pipes