

Table of Contents

1.0 Table of Contents

1.1 System description

- 1.100 System description (general)
- 1.105 System description (data)
- 1.106 System description (data)
- 1.110 Long-term behaviour/lifetime calculation
- 1.115 CALPEX PUR-KING UNO range, heating 6 bar – structure, dimensions, materials, weights and delivery lengths
- 1.116 CALPEX PUR-KING DUO range, heating 6 bar – structure, dimensions, materials, weights and delivery lengths
- 1.120 CALPEX PUR-KING UNO/DUO range, sanitary 10 bar – structure, dimensions, materials, weights and delivery lengths
- 1.125 CALPEX QUADRIGA range, heating 6 bar, sanitary 10 bar – structure, dimensions, materials, weights and delivery lengths

1.2 Planning, design engineering

- 1.200 Pressure loss chart CALPEX PUR-KING, heating, 6 bar
- 1.205 Pressure loss chart CALPEX SANITARY, sanitary, 10 bar
- 1.210 Heat loss CALPEX PUR-KING, heating, 6 bar
- 1.215 Heat loss CALPEX SANITARY, sanitary, 10 bar
- 1.220 Heat loss CALPEX QUADRIGA, heating 6 bar, sanitary 10 bar
- 1.225 Planning and connection technology, heating strip, sanitary, 10 bar

1.3 Components

- 1.300 House entry bend 90° CALPEX PUR-KING, heating 6 bar, UNO
- 1.301 House entry bend 90° CALPEX PUR-KING, heating 6 bar, DUO
- 1.305 House entry bend 90° CALPEX SANITARY, sanitary 10 bar, UNO and DUO
- 1.310 House entry bend 90° CALPEX QUADRIGA, heating 6 bar, sanitary 10 bar
- 1.315 CALPEX L-shell
- 1.316 CALPEX Big L-shell
- 1.320 Joint (PE-HD shrink sleeve)
- 1.325 CALPEX I-shell
- 1.326 CALPEX Big I-shell
- 1.330 CALPEX T-shell
- 1.335 CALPEX Big T-shell

- 1.340 T-joint
- 1.345 Y-pipe CALPEX PUR-KING, heating, 6 bar
- 1.350 Distribution chamber
- 1.355 Distribution chamber, installation
- 1.360 Concrete protective plate for distribution shaft
- 1.365 Insulation material, PE foam PUR foam containers
- 1.370 Screwed connectors, outer thread, weld end
- 1.375 Screwed connectors, coupling: equal, reduced
- 1.380 Compression connectors, thread, weld end with sliding sleeve
- 1.385 Compression connectors, coupling, angle 90° with sliding sleeve
- 1.390 Compression T-piece, with sliding sleeve, heating 6 bar
- 1.395 Compression T-piece, with sliding sleeve, sanitary 10 bar
- 1.400 Electro-fusion joint
- 1.405 End cap, standard, shrinkable
- 1.410 Wall sealing ring, for wall openings
- 1.415 Building entry, wall opening/core bore
- 1.420 Wall seal, core bores/cement pipe liners
- 1.425 Building entry, core bores/cement pipe liners

1.5 Underground construction, installation

- 1.500 Pipe routing
- 1.505 Trench dimensions
- 1.510 Pipe warning tape, laying tools
- 1.515 Connection (rigid/flexible), CALPEX plastic casing pipe
- 1.520 House entry, screwed connector, shaft entry, fixed point forces
- 1.525 House connection, compression joint, shaft entry, fixed point forces
- 1.530 Installation of house entry
- 1.535 Installation tool, general and for screwed connector
- 1.540 Installation tool, for joint with sliding sleeves
- 1.545 Heating strip CALPEX SANITARY, sanitary, 10 bar, drawing in, sensor, joint

System description

1. General

CALPEX is the protected name for a flexible pipe system of BRUGG Pipesystems, especially for the low-temperature range and is produced according to the current standard (EN 15632-1/-2).

CALPEX PUR-KING, the district heating pipe, and CALPEX SANITARY, the service water pipe, are intended for use in small and medium-sized district and local heating networks as well as in industry and agriculture, in drinking water supplies, sewage systems, chillers and in swimming pool technology.

The CALPEX systems consist of a carrier pipe made of cross-linked polyethylene PEXa and are equipped with an organic oxygen diffusion barrier (EVOH).

The carrier pipe was selected or integrated into the standards because it has excellent thermal and mechanical properties. The corrosion-resistant, chemically resistant material is very robust and can very easily be processed by hand.

The thermal insulation of CALPEX PUR-KING consists of a patented flexible polyurethane rigid foam with excellent thermal insulation properties. This insulating material is produced by a chemical reaction. CALPEX PUR-KING has an extremely closed-cell structure, as a result of which its thermal insulation is improved considerably and remains stable for decades.

CALPEX is free of harmful substances and therefore extremely environmentally friendly.

During the formation of the foam, the carrier pipes are wetted very effectively by it, resulting in a firm adhesion and a force-locking bond. The physical properties of the PEXa pipe combined with the insulation bond allow installation without having to take thermal expansion into account.

The ability to bend the CALPEX systems allows them to be adapted to all conditions along the pipe route with ease.

Existing supply lines can be crossed by going under or over them; obstacles can easily be bypassed. With CALPEX systems, users can choose the shortest pipe route without the restrictions required by the classical method of pipe construction.

The CALPEX systems are delivered to the construction site in the desired length, in endless rings, or on a cable drum. Long delivery lengths enable pipes to be laid in the ground largely without joints. This means that the pipe trench can be considerably narrower. This allows considerable savings to be made in civil engineering work. This applies in particular to DUO lines.

If one also considers the very short installation time, the CALPEX systems are not only a technically perfect solution, but also the key to the time and cost-saving creation of district heating or service water networks due to the reduced amount of coordination work required on site and the quick and easy installation.

Assembling the connection pieces could hardly be easier. With conventional screw connections, press fittings or electrofusion couplers, the connections are quickly and safely installed. The wide range of accessories ensures that solutions can be chosen for every possible situation.

2. Range of applications

Heating, pipe series 5 (SDR 11):

Max. permitted
operating temp. T_{max} : 95°C (fluctuating)
Max. permitted
operating pressure p: 6 bar

see sheet CPX 1.110

Sanitary, pipe series 3.2 (SDR 7.4):

Max. permitted
operating temp. T_{max} : 95°C (fluctuating)
Max. permitted
operating pressure p: 10 bar

see sheet CPX 1.110

System description

1. Bonded system

Requirements	Factory insulated, flexible pipe systems according EN 15632-1/-2
Fire behaviour	Building material class B2 (normally flammable) according to DIN 4102

2. Carrier pipe

Materials	Basic material: High-density polyethylene (PE-HD), peroxide cross-linked (PEXa), colour: natural
Bonding agent	PE-modified, heat-stabilized, colour: red (heating), silver (sanitary)
Oxygen barrier layer	Ethylene / vinyl alcohol (EVOH), heat-stabilized, colour: natural
Requirements	As per DIN 16892 / DIN 16893 and E DIN EN 12318-2, pipes in series 3.2 as per DVGW worksheet W 544
Impermeability to oxygen	As per DIN 4729 at 40 °C, oxygen permeability based on the interior pipe volume as per DIN 4726 from $\leq 0.10 \text{ g} / (\text{m}^3 \times \text{d})$
Pipe series DIN 16893	Series 5 (SDR 11): for CALPEX PUR-KING (with EVOH barrier) Series 3.2 (SDR 7.4): for CALPEX SANITARY (with EVOH barrier)
Long-term behaviour	See catalog sheet CPX 1.110
Properties	Unaffected by aggressive water; low pressure losses; very good chemical and mechanical resistance (DIN 8075 sheet 1)

PEXa carrier pipe	Reference temperature °C	Value	Test standard
Density	-	932 - 935 kg/m ³	ISO 1183
Thermal conductivity	-	0.38 W/mK	according to ASTM C 1113
Tensile strength	20	min. 18 N/mm ²	ISO 6259
Tensile strength	80	min. 8 N/mm ²	ISO 6259
Linear expansion coefficient	20	$1.4 \cdot 10^{-4} 1/K$	-
Linear expansion coefficient	100	$2.0 \cdot 10^{-4} 1/K$	-
Crystallite melting range	-	128 - 134 °C	-
Chem. resistance	20 / 40 / 60	-	DIN 8075 B.1

System description

3. Thermal insulation

Materials

CALPEX PUR-KING (heating 6 bar)

CFC-free polyurethane foam (PUR) according to PUR-KING technology

CALPEX SANITARY (sanitary 10 bar)

CFC-free, 100 % CO₂-blown polyurethane foam (PUR)

PUR insulation	Reference temperature °C	CALPEX PUR-KING	CALPEX SANITARY	Test standard
Density	-	> 50 kg/m ³	> 50 kg/m ³	EN 253
Axial shear strength	-	-	≥ 90 kPa	EN 15632-2
Thermal conductivity flexible systems	50	≤ 0.0199 W/mK	≤ 0.0234 W/mK	EN 253 and ISO 8497
Thermal conductivity rigid systems	50	≤ 0.0260 W/mK	-	EN 253 and ISO 8497
Percentage of closed cells	-	≥ 88 %	≥ 90 %	EN 253
Water absorption	100	≤ 10 %	≤ 10 %	EN 15632-1

4. Protective casing

Materials

linear polyethylene, low density (LLD-PE), seamlessly extruded

Purpose

mechanical protection and moisture resistance

LLD-PE protective casing	Reference temperature °C	Value	Test standard
Density	-	918 - 922 kg/m ³	ASTM D792
Thermal conductivity	-	0.33 W/mK	DIN 52612
Graphite content	-	> 2%	EN 15632-1

Long-term behaviour

Service life calculation

Safety factor	Operating temperature °C	CALPEX PUR-KING (pipe series 5 / SDR 11) Years						CALPEX-Sanitary (pipe series 3.2 / SDR 7.4) Years					
		1	5	10	25	50	100	1	5	10	25	50	100
1.5	10	17.9	14.6	14.5	14.4	14.2	14.1	23.6	23.2	23.0	22.8	22.6	22.4
1.5	20	13.2	12.9	12.8	12.7	12.6	12.5	20.9	20.5	20.4	20.1	20.0	19.8
1.5	30	11.7	11.5	11.4	11.3	11.2	11.1	18.5	18.2	18.1	17.9	17.7	17.6
1.5	40	10.4	10.2	10.1	10.0	9.9	9.8	16.5	16.2	16.1	15.9	15.7	15.6
1.5	50	9.3	9.1	9.0	8.9	8.8	8.8	14.7	14.4	14.3	14.1	14.0	13.9
1.5	60	8.3	8.1	8.0	7.9	7.9	-	13.1	12.9	12.8	12.6	12.5	-
1.5	70	7.4	7.3	7.2	7.1	7.0	-	11.8	11.5	11.4	11.3	11.2	-
1.5	80	6.6	6.5	6.4	(6.4) ^a	-	-	10.5	10.3	10.2	10.1	-	-
1.3	90	6.9	6.7	6.6	-	-	-	11.0	10.7	10.6	-	-	-
1.3	95	6.5	6.3	6.3	-	-	-	10.4	10.2	10.1	-	-	-

The values in brackets apply to verification of test times longer than one year for the 110 °C test

Long-term behaviour

The permissible operating pressures according to DIN 16892/3 and 15632-2 are based on water as a flow medium and have been designed with a safety factor:

Temperature	Safety factor	Temperature range
Operating temperature (T _{op})	1.5	≤ 80 °C
Maximum operating temperature (T _{max})	1.3	> 80 °C to ≤ 95 °C
Fault temperature (T _{mal})	1.0	> 95 °C to ≤ 110 °C

^a The specified temperature range defines the safety factors that must be applied to temperature/time profiles deviating from Table 1 and calculated in line with Appendix A.

The values are monitored by the plastic pipe producer through long-term studies and are confirmed and tested by independent test institutes. The max. operating temperature is between 81°C and 95°C; however, a short-term overtemperature (fault temperature) of 96°C to 110°C is considered.

A typical smooth temperature distribution in the flow in the district heating systems results in an average temperature/year of approx. 66°C.

For the use of a PEX pipe system with changing operating temperatures, the operating time can be calculated using Miner's rule.

Usage examples

Operating temperature °C	Example 1 Annual operating duration h	Example 2 Annual operating duration h	Example 3 Annual operating duration h	Example 4 Annual operating duration h
50	0	0	185	0
55	0	0	160	4380
60	0	0	145	4380
65	0	535	130	0
70	0	3720	120	0
75	0	840	115	0
80	8468	3500	110	0
85	0	165	4500	0
90	258.7	0	0	0
95	33.3	0	0	0
Operating duration h/a	8760	8760	5465	8760
Calculated service life	30 years + 100 h	> 50 years	> 30 years	> 100 years ^a

Pipe systems that comply with the EN 15632-2 standard are designed for a service life of at least 30 years as long as they are operated at the following temperature profile:

29 years at 80 °C
 + 1 year at 90 °C
 + 100 h at 95 °C

 30 years + 100 h

CALPEX PUR-KING

CALPEX PUR-KING UNO (heating, 6 bar)

CALPEX PUR-KING

in coils:

Dimensions:

CPX Ø 76 - 202 mm

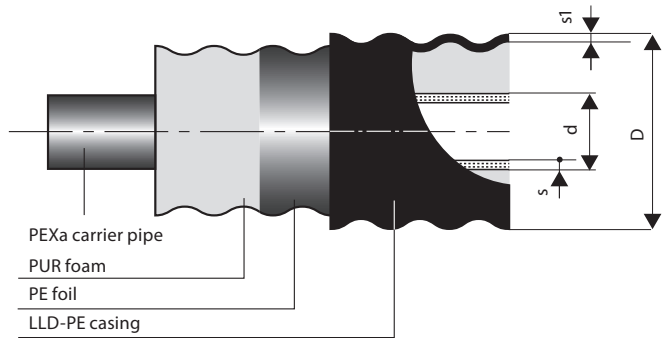
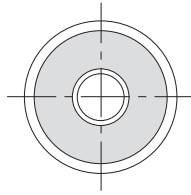

CALPEX PUR-KING

in straight lengths:

Dimensions:

CPX Ø 250 mm

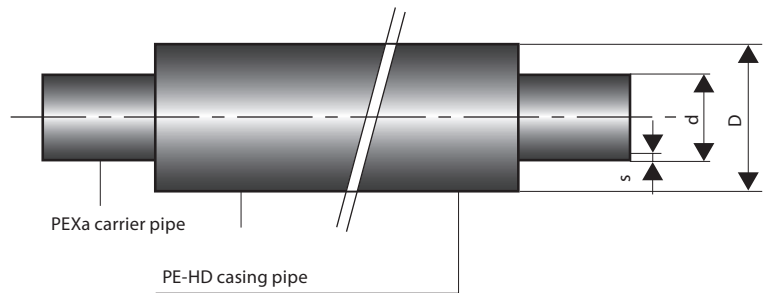
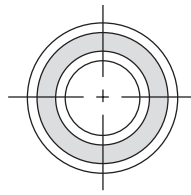

CALPEX PUR-KING heating, 6 bar, UNO

Type	PEX carrier pipe d x s mm	Nominal diameter		Outer casing D x s1 mm	Minimum bending radius m	Volume Carrier pipe l/m	Weight kg/m	Maximum delivery lengths*	
		DN	Inches "					Jumbo Coil m	Maxi Coil m
25/ 76	25 x 2.3	20	¾	78 x 1.9	0.45	0.327	0.90	700	1000
25/ 91 PLUS				93 x 2.1	0.65	0.327	1.20	450	715
32/ 76	32 x 2.9	25	1	78 x 1.9	0.50	0.539	1.00	700	1000
32/ 91 PLUS				93 x 2.1	0.70	0.539	1.40	450	715
40/ 91	40 x 3.7	32	1¼	93 x 2.1	0.55	0.835	1.40	450	715
40/111 PLUS				113 x 2.3	0.75	0.835	1.70	300	450
50/111	50 x 4.6	40	1½	113 x 2.3	0.60	1.307	1.97	300	450
50/126 PLUS				128 x 2.7	0.80	1.307	2.40	192	350
63/126	63 x 5.8	50	2	128 x 2.7	0.65	2.075	2.60	192	350
63/142 PLUS				143 x 2.9	0.85	2.075	3.10	160	260
75/142	75 x 6.8	65	2½	143 x 2.9	0.70	2.961	3.39	160	260
75/162 PLUS				163 x 3.2	0.90	2.961	3.90	92	150
90/162	90 x 8.2	80	3	163 x 3.2	1.00	4.254	4.56	92	150
90/182 PLUS				183 x 3.3	1.20	4.254	4.80	52	90
110/162	110 x 10.0	100	4	163 x 3.2	1.10	6.362	5.70	92	150
110/182				183 x 3.3	1.20	6.362	6.60	52	90
110/202 PLUS**				202 x 3.3	1.40	6.362	6.80	46	80
125/182	125 x 11.4	125	5	183 x 3.3	1.30	8.203	7.20	52	90
125/202 PLUS**				202 x 3.3	1.50	8.203	7.80	46	80
140/202	140 x 12.7	125	5	202 x 3.3	1.40	10.315	8.40	46	80
160/250	160 x 14.6	150	6	250 x 3.9	-	13.437	11.80	12	12*

* Supply as section length, as coils and on drums possible. The delivered coil length may vary (+/- 5%)

** Available on request

- We will produce different dimensions or special items on request.
- Larger or smaller delivery lengths can be supplied on drums if requested.
- Coil dimensions: **Jumbo coil** outer diameter 2800 mm x 800 mm (width)
Maxi coil outer diameter 2800 mm x 1200 mm (width)

When ordering at the construction site, please observe the total weight of the coil (unwinding equipment)

CALPEX PUR-KING range

CALPEX PUR-KING DUO (heating, 6 bar)

CALPEX PUR-KING in coils:

Dimensions:
CPX Ø 76 - 202 mm

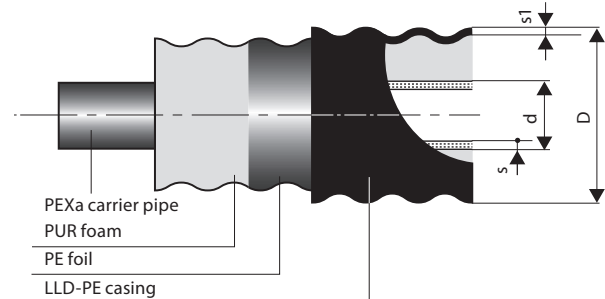
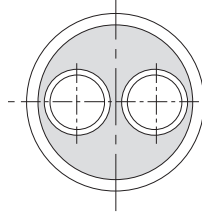

CALPEX PUR-KING heating, 6 bar, DUO

Type	PEX carrier pipe d x s mm	Nominal diameter		Outer casing D x s1 mm	Minimum bending radius m	Volume Carrier pipe l/m	Weight kg/m	Maximum delivery lengths*	
		DN	Inches "					Jumbo coil m	Maxi coil m
25 + 25/ 91	2 x 25 x 2.3	20 + 20	2 x ¾	93 x 2.1	0.55	2 x 0.327	1.34	450	715
25 + 25/111 PLUS				113 x 2.3	0.75	2 x 0.327	1.60	300	450
32 + 32/111	2 x 32 x 2.9	25 + 25	2 x 1	113 x 2.3	0.60	2 x 0.539	1.90	300	450
32 + 32/126 PLUS				128 x 2.7	0.80	2 x 0.539	2.30	192	350
40 + 40/126	2 x 40 x 3.7	32 + 32	2 x 1¼	128 x 2.7	0.65	2 x 0.835	2.50	192	350
40 + 40/142 PLUS				143 x 2.9	0.85	2 x 0.835	3.00	160	260
50 + 50/162	2 x 50 x 4.6	40 + 40	2 x 1½	163 x 3.2	1.10	2 x 1.307	4.00	92	150
50 + 50/182 PLUS				183 x 3.3	1.30	2 x 1.307	4.70	52	90
63 + 63/182	2 x 63 x 5.8	50 + 50	2 x 2	183 x 3.3	1.20	2 x 2.075	5.30	52	90
63 + 63/202 PLUS**				202 x 3.3	1.40	2 x 2.075	6.00	46	80
75 + 75/202**	2 x 75 x 6.8	65 + 65	2 x 2½	202 x 3.3	1.40	2 x 2.961	6.90	46	80

* Supply as section length, as coils and on drums possible. The delivered coil length may vary (+/- 5%)

** Available on request

- We will produce different dimensions or special items on request.
- Larger or smaller delivery lengths can be supplied on drums if requested.
- Coil dimensions: **Jumbo coil** outer diameter 2800 mm x 800 mm (width)
Maxi coil outer diameter 2800 mm x 1200 mm (width)

When ordering at the construction site, please observe the total weight of the coil (unwinding equipment)

CALPEX SANITARY range

CALPEX SANITARY UNO/DUO (sanitary 10 bar)

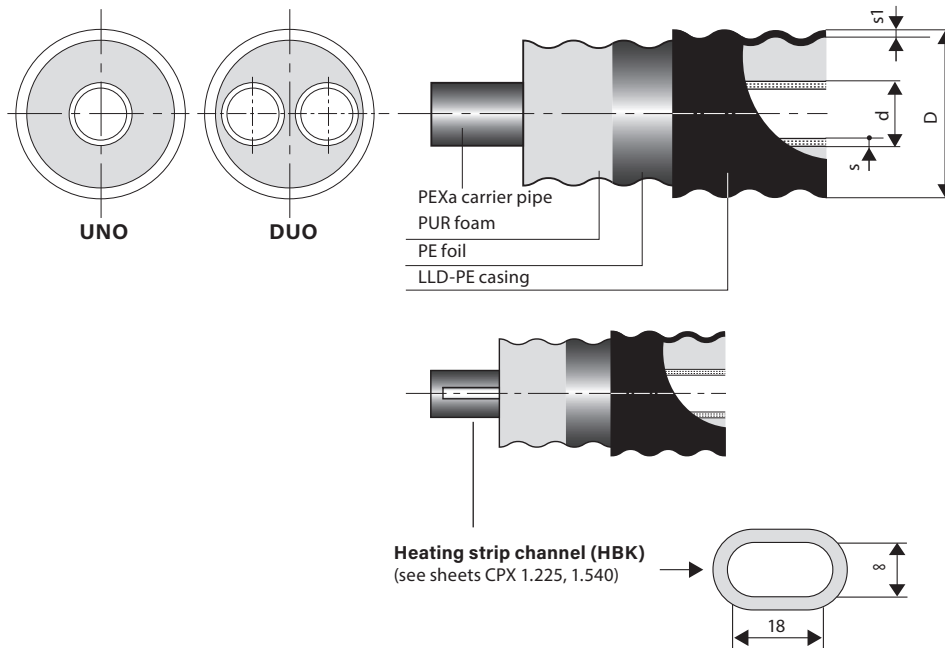

CALPEX SANITARY 10 bar, UNO

Type	Nominal diameter		PEX carrier pipe d x s mm	Outer casing D x s1 mm	Minimum bending radius m	Volume carrier pipe l/m	Weight kg/m	Maximum delivery lengths*	
	DN	Inches "						Jumbo coil m	Maxi coil m
20/ 76	16	5/8	20 x 2.8	78 x 2.0	0.45	0.163	0.96	700	1000
25/ 76	20	3/4	25 x 3.5	78 x 2.0	0.50	0.254	1.06	700	1000
32/ 76	25	1	32 x 4.4	78 x 2.0	0.50	0.423	1.25	700	1000
40/ 91	32	1 1/4	40 x 5.5	93 x 2.2	0.55	0.661	1.77	450	715
50/111	40	1 1/2	50 x 6.9	113 x 2.4	0.60	1.029	2.50	300	450
63/126	50	2	63 x 8.7	128 x 2.7	0.65	1.633	3.40	192	350
32/111 HBK	25	1	32 x 4.4	113 x 2.4	0.60	0.423	1.83	300	450
50/126 HBK	40	1 1/2	50 x 6.9	128 x 2.7	1.00	1.029	2.76	192	350

CALPEX SANITARY 10 bar, DUO

Type	Nominal diameter		PEX carrier pipe d x s mm	Outer casing D x s1 mm	Minimum bending radius m	Volume carrier pipe l/m	Weight kg/m	Maximum delivery lengths*	
	DN	Inches "						Jumbo coil m	Maxi coil m
25 + 20/ 91	20 + 16	3/4 + 5/8	25 x 3.5 + 20 x 2.8	93 x 2.2	0.55	0.254 + 0.163	1.47	450	715
32 + 20/111	25 + 16	1 + 5/8	32 x 4.4 + 20 x 2.8	113 x 2.4	0.60	0.423 + 0.163	1.95	300	450
40 + 25/126	32 + 20	1 1/4 + 3/4	40 x 5.5 + 25 x 3.5	128 x 2.7	0.65	0.661 + 0.254	2.60	192	350
50 + 32/126	40 + 25	1 1/2 + 1	50 x 6.9 + 32 x 4.4	128 x 2.7	0.65	1.029 + 0.423	1.77	192	350

* Supply as section length, as coils and on drums possible. The delivered coil length may vary (+/- 5%)

- We will produce larger dimensions on request (Ø 75, 90, 110, 125 mm)
- Larger or smaller delivery lengths can be supplied on drums if requested.
- Coil dimensions: **Jumbo coil** outer diameter 2800 mm x 800 mm (width)
Maxi coil outer diameter 2800 mm x 1200 mm (width)

When ordering at the construction site, please observe the total weight of the coil (unwinding equipment)

CALPEX QUADRIGA range

CALPEX QUADRIGA (Heating 6 bar, sanitary 10 bar)

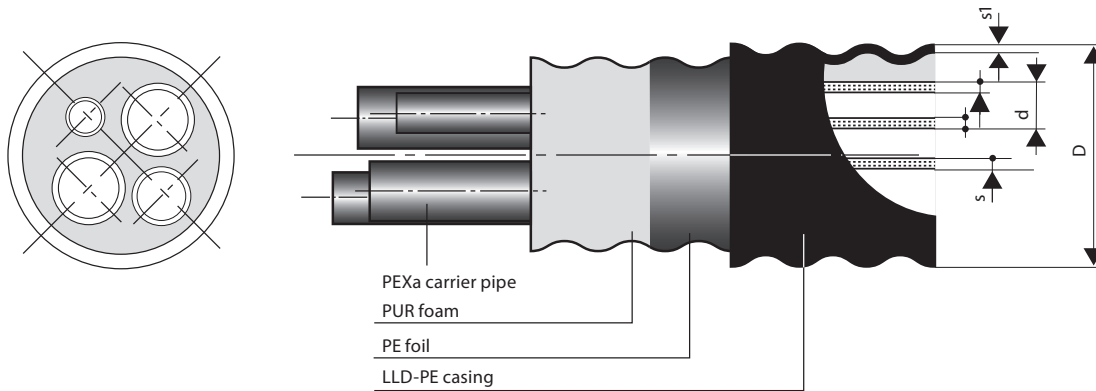

CALPEX, heating 6 bar, sanitary 10 bar, QUADRIGA

Type	Nominal diameter		Carrier pipe	Outer casing	Minimum bending radius	Volume carrier pipe	Weight	Maximum delivery length*	
	DN	Inches	d x s	D x s1				Jumbo coil	Maxi coil
		"	mm	mm	m	l/m	kg/m	m	m
H25 + 25/S25 + 20/142	20	¾	25 x 2.3	143 x 3.0	0.7	0.327	3.25	110	180
	20	¾	25 x 2.3			0.327			
	20	¾	25 x 3.5			0.254			
	16	⅝	20 x 2.8			0.163			
H32 + 32/S25 + 20/142	25	1	32 x 2.9	143 x 3.0	0.7	0.539	3.39	110	180
	25	1	32 x 2.9			0.539			
	20	¾	25 x 3.5			0.254			
	16	⅝	20 x 2.8			0.163			
H32 + 32/S32 + 20/142	25	1	32 x 2.9	143 x 3.0	0.7	0.539	3.41	110	180
	25	1	32 x 2.9			0.539			
	25	1	32 x 4.4			0.423			
	16	⅝	20 x 2.8			0.163			
H40 + 40/S40 + 25/162	32	1¼	40 x 3.7	163 x 3.2	1.1	0.835	4.15	65	105
	32	1¼	40 x 3.7			0.835			
	32	1¼	40 x 5.5			0.661			
	20	¾	25 x 3.5			0.254			

* Supply as section length, as coils and on drums possible. The delivered coil length may vary (+/- 5%)

- We will produce different dimensions or special items on request.
- Larger or smaller delivery lengths can be supplied on drums if requested.
- Coil dimensions: **Jumbo coil** outer diameter 2800 mm x 800 mm (width)
Maxi coil outer diameter 2800 mm x 1200 mm (width)

When ordering at the construction site, please observe the total weight of the coil (unwinding equipment)

Pressure loss chart

CALPEX PUR-KING (Heating, 6 bar)

Water temperature 80 °C

Surface roughness $\epsilon = 0.007$ mm (PEXa)

(1 mmWS = 9.81 Pa)

$\dot{m} \approx \frac{Q \cdot 860}{\Delta T}$	\dot{m} =	Flow rate in kg/h
	Q =	Power requirement in kW
	ΔT =	Temperature difference VL (flow)/RL (return) in °C

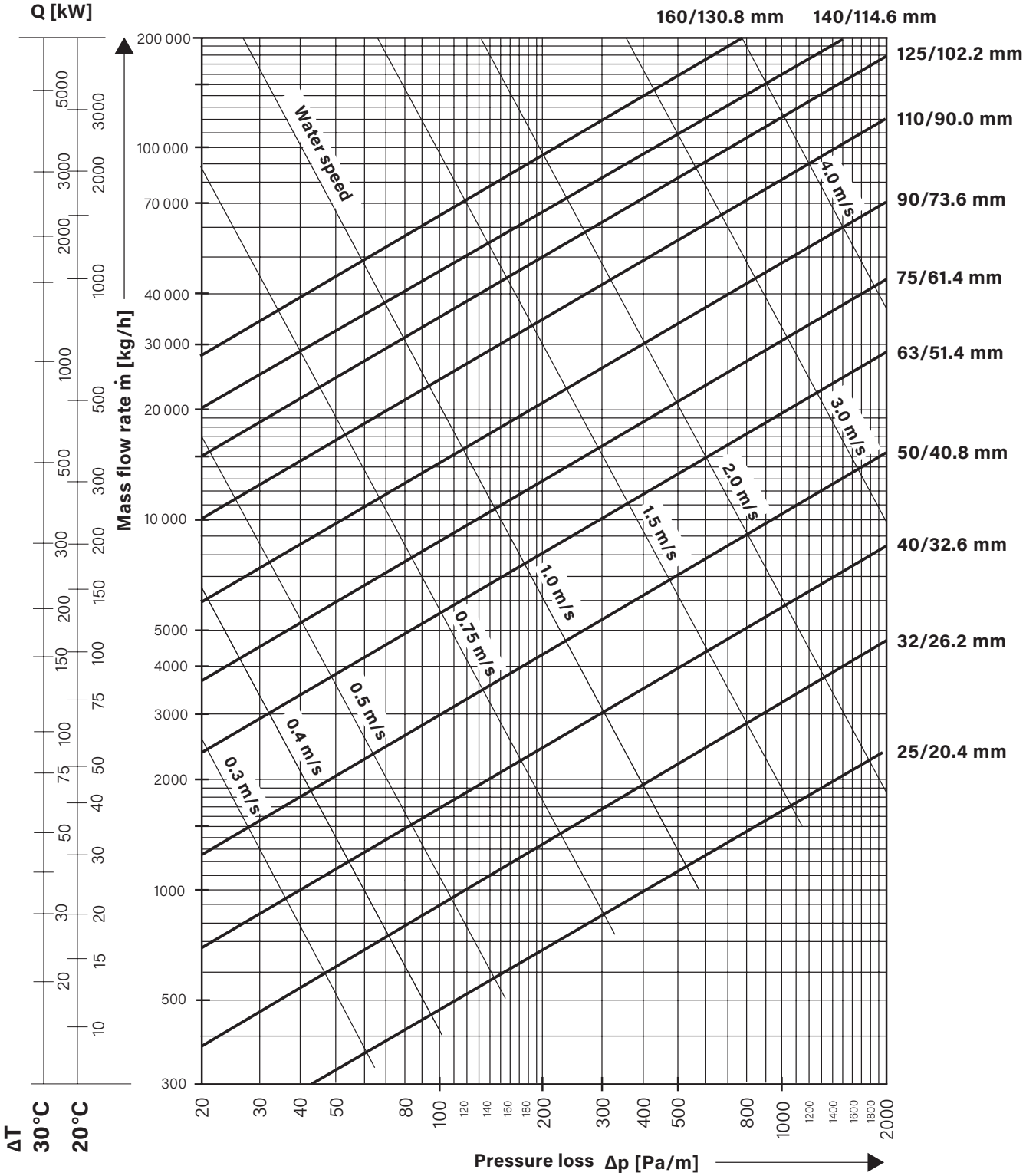

Pressure loss chart

CALPEX SANITARY (Sanitary 10 bar)

Water temperature 60 °C

Surface roughness $\epsilon = 0.007$ mm (PEXa)

(1 mmWS = 9.81 Pa)

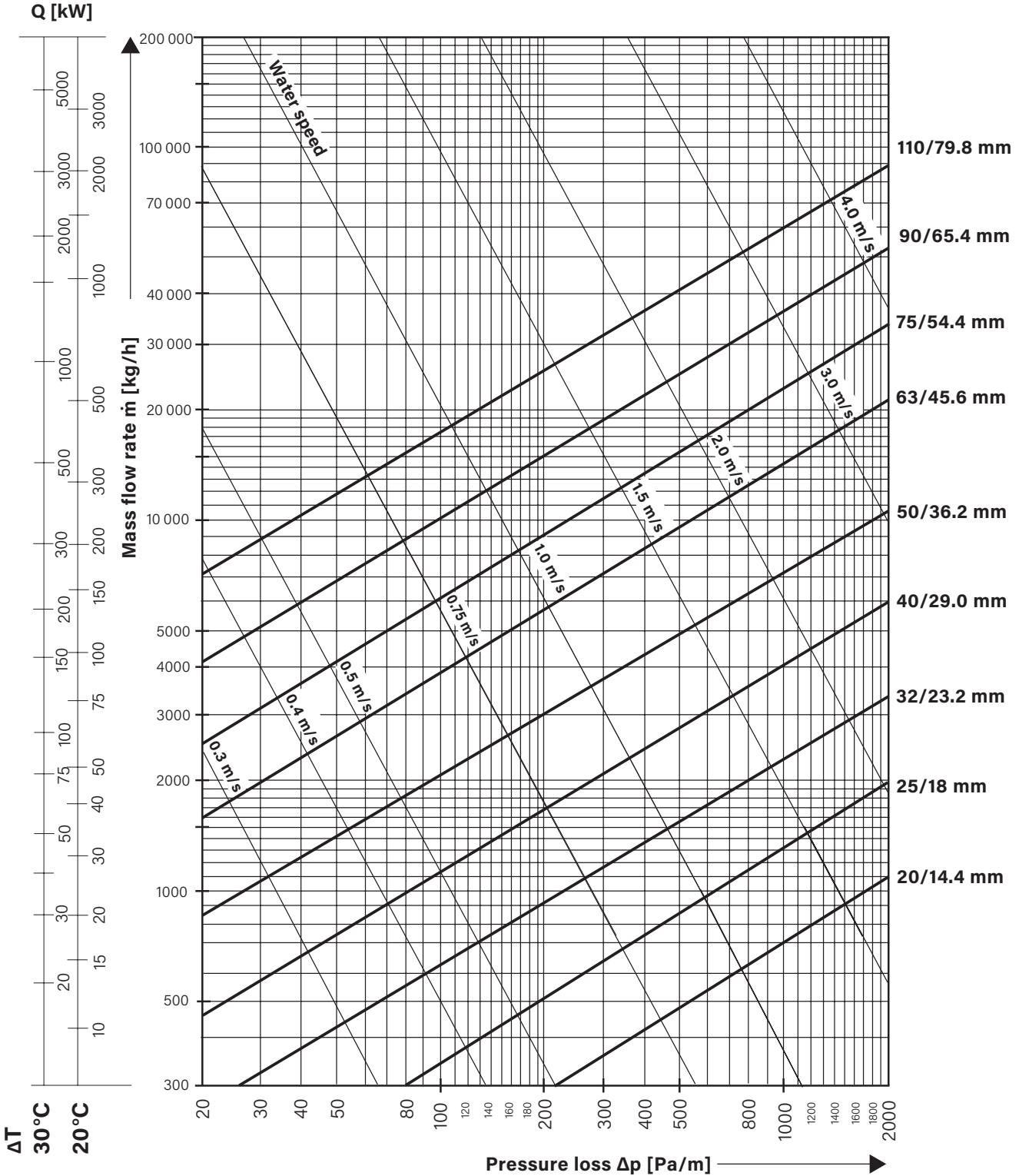

Heat loss

CALPEX PUR-KING (Heating 6 bar)

CALPEX PUR-KING UNO

Heat losses q [W/m] for one UNO pipe						
Type	U-value [W/mK]	Average operating temperature T _B [°C]				
		40°	50°	60°	70°	80°
25/ 76	0.1050	3.15	4.20	5.25	6.30	7.35
25/ 91 PLUS	0.0910	2.73	3.64	4.55	5.46	6.37
32/ 76	0.1320	3.96	5.28	6.60	7.92	9.24
32/ 91 PLUS	0.1110	3.33	4.44	5.55	6.66	7.77
40/ 91	0.1380	4.14	5.52	6.90	8.28	9.66
40/111 PLUS	0.1140	3.42	4.56	5.70	6.84	7.98
50/111	0.1420	4.26	5.68	7.10	8.52	9.94
50/126 PLUS	0.1260	3.78	5.04	6.30	7.56	8.82
63/126	0.1620	4.86	6.48	8.10	9.72	11.34
63/142 PLUS	0.1420	4.26	5.68	7.10	8.52	9.94
75/142	0.1750	5.25	7.00	8.75	10.50	12.25
75/162 PLUS	0.1490	4.47	5.96	7.45	8.94	10.43
90/162	0.1903	5.71	7.61	9.52	11.42	13.32
90/182 PLUS	0.1615	4.85	6.46	8.08	9.69	11.31
110/162	0.2740	8.22	10.96	13.70	16.44	19.18
110/182	0.2181	6.54	8.72	10.91	13.09	15.27
110/202 PLUS	0.1856	5.57	7.42	9.28	11.14	12.99
125/182	0.2807	8.42	11.23	14.04	16.84	19.65
125/202 PLUS	0.2290	6.87	9.16	11.45	13.74	16.03
140/202	0.2891	8.67	11.56	14.46	17.35	20.24
160/250*	0.3028	9.08	12.11	15.14	18.17	21.20

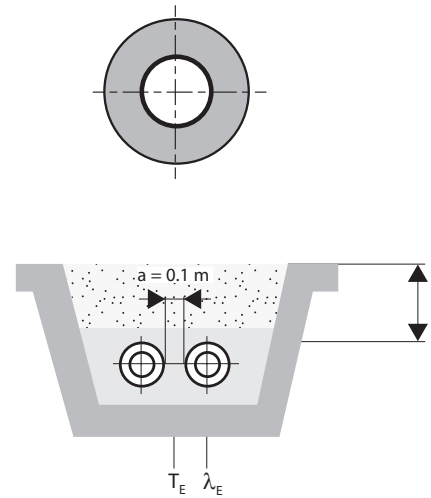

CALPEX PUR-KING DUO

(flow and return in one pipe)

Heat losses q [W/m] for one DUO pipe						
Type	U-value [W/mK]	Average operating temperature T _B [°C]				
		40°	50°	60°	70°	80°
25 + 25/ 91	0.1635	4.91	6.54	8.18	9.81	11.45
25 + 25/111 PLUS	0.1285	3.86	5.14	6.43	7.71	9.00
32 + 32/111	0.1690	5.07	6.76	8.45	10.14	11.83
32 + 32/126 PLUS	0.1431	4.29	5.72	7.16	8.59	10.02
40 + 40/126	0.1909	5.73	7.64	9.55	11.45	13.36
40 + 40/142 PLUS	0.1594	4.78	6.38	7.97	9.56	11.16
50 + 50/162	0.1780	5.34	7.12	8.90	10.68	12.46
50 + 50/182 PLUS	0.1510	4.53	6.04	7.55	9.06	10.57
63 + 63/182	0.2130	6.39	8.52	10.65	12.78	14.91
63 + 63/202 PLUS	0.1780	5.34	7.12	8.90	10.68	12.46
75 + 75/202	0.2430	7.29	9.72	12.15	14.58	17.01

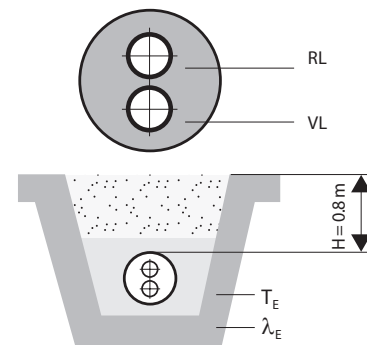

- Type of installation, CPX UNO: 2-pipe, laid in the ground
- Type of installation, CPX DUO: 1-pipe, laid in the ground
- Pipe distance: a = 0.10 m
- Cover above pipe: H = 0.80 m
- Ground temperature: T_E = 10 °C
- Soil conductivity: λ_E = 1.0 W/mK
- Conductivity of PUR-KING foam: λ_{PU} = 0.0199 W/mK
- * Conductivity of PUR foam: λ_{PU} = 0.0260 W/mK
- Conductivity of PEX pipe: λ_{PEXa} = 0.38 W/mK
- Conductivity of PE pipe: λ_{PE} = 0.33 W/mK

Heat loss during operation:

- q = U (T_B - T_E) [W/m]**
- U = Heat transfer coefficient [W/mK]
- T_B = Average operating temperature [°C]
- T_E = Average ground temperature [°C]
- VL = Flow
- RL = Return

Heat loss

CALPEX SANITARY (Sanitary 10 bar)

CALPEX SANITARY UNO

Heat losses q [W/m] for one UNO pipe						
Type	U-value [W/mK]	Average operating temperature T _B [°C]				
		40°	50°	60°	70°	80°
20/ 76	0.1009	3.03	4.04	5.05	6.05	7.06
25/ 76	0.1192	3.58	4.77	5.96	7.15	8.34
32/ 76	0.1588	4.76	6.35	7.94	9.53	11.12
40/ 91	0.1666	5.00	6.66	8.33	10.00	11.66
50/111	0.1713	5.14	6.85	8.57	10.28	11.99
63/126	0.1957	5.87	7.83	9.79	11.74	13.70
32/111 HBK	0.1127	3.38	4.51	5.64	6.76	7.89
50/126 HBK	0.1497	4.49	5.99	7.49	8.98	10.48

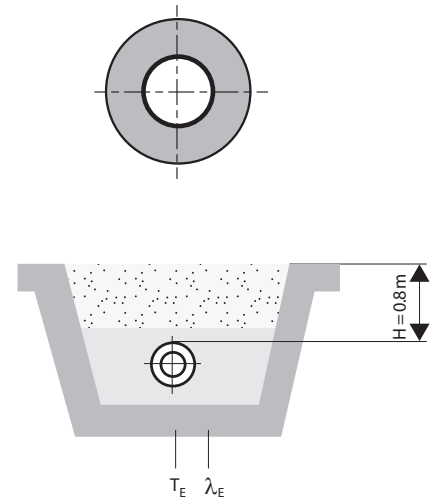

CALPEX SANITARY DUO

Heat losses q [W/m] for one DUO pipe						
Type	U-value [W/mK]	Average operating temperature T _B [°C]				
		40°	50°	60°	70°	80°
25 + 20/ 91	0.1710	5.13	6.84	8.55	10.26	11.97
32 + 20/111	0.1630	4.89	6.52	8.15	9.78	11.41
40 + 25/126	0.1780	5.34	7.12	8.90	10.68	12.46
50 + 32/126	0.2476	7.43	9.90	12.38	14.86	17.33

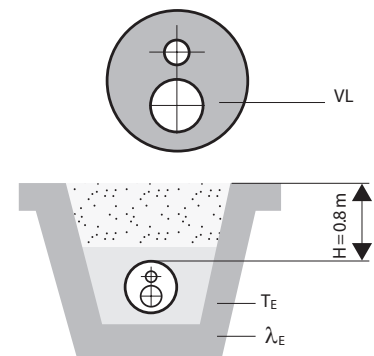

Type of installation, CPX UNO:	1-pipe, laid in the ground
Type of installation, CPX DUO:	1-pipe, laid in the ground
Cover above pipe:	H = 0.80 m
Ground temperature:	T _E = 10 °C
Soil conductivity:	λ _E = 1.0 W/mK
Conductivity of PUR foam:	λ _{PU} = 0.0234 W/mK
Conductivity of PEX pipe:	λ _{PEXa} = 0.38 W/mK
Conductivity of PE pipe:	λ _{PE} = 0.33 W/mK

Heat loss during operation:

$$q = U (T_B - T_E) \text{ [W/m]}$$

U = Heat transfer coefficient [W/mK]

T_B = Average operating temperature [°C]

T_E = Average ground temperature [°C]

Heat loss

CALPEX QUADRIGA (Heating 6 bar, Sanitary 10 bar)

CALPEX QUADRIGA

Heat losses q [W/m] for one QUADRIGA pipe					
Type	U-value [W/mK]	Average operating temperature T _B [°C]			
		50°	55°	60°	65°
H 25 + 25/S 25 + 20/142	0.1542	6.17	6.94	7.71	8.48
H 32 + 32/S 25 + 20/142	0.1785	7.14	8.03	8.93	9.82
H 32 + 32/S 32 + 20/142	0.1930	7.72	8.69	9.65	10.62
H 40 + 40/S 40 + 25/162	0.2279	9.12	10.26	11.40	12.53

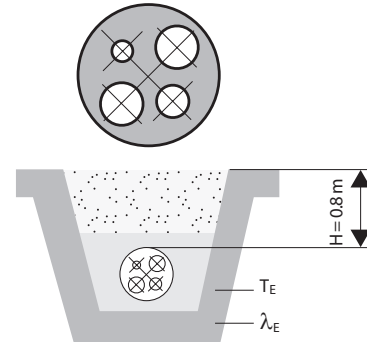

Type of installation for QUADRIGA: 1-pipe, laid in the ground
 Cover above pipe: H = 0.80 m
 Ground temperature: T_E = 10 °C
 Soil conductivity: λ_E = 1.0 W/mK
 Conductivity of PUR foam: λ_{PU} = 0.0234 W/mK
 Conductivity of PEXa pipe: λ_{PEX} = 0.38 W/mK
 Conductivity of PE pipe: λ_{PE} = 0.33 W/mK

Heat loss during operation:

$$q = U (T_B - T_E) \text{ [W/m]}$$

U = Heat transfer coefficient [W/mK]

T_B = Average operating temperature [°C]

T_E = Average ground temperature [°C]

CALPEX QUADRIGA - heat loss during operation

Example of calculation for average operating temperature T_B [°C]

Flow - heating: 70 °C

Return - heating: 40 °C

Flow - sanitary: 60 °C

Return - sanitary: 50 °C

$$T_B = \frac{70^\circ + 40^\circ + 60^\circ + 50^\circ}{4} = 55^\circ \text{ C}$$

Planning and connection technology

CALPEX SANITARY (Heating strip)

1. Requirements for heating strip

1.1 Minimum power

Type CALPEX UNO	In relation to a maintained temperature of:		
	40 °C	50 °C	60 °C
32/111	5.8 W/m	7.8 W/m	9.6 W/m
50/126	7.3 W/m	10.3 W/m	12.8 W/m

1.2 Recommendations for heating strip

Hot water:

HWAT-R from Tyco Thermal Controls N.V. meets the requirement for Ø 50/126, 60 °C
Automatic power adjustment with HWAT-ECO

Frost protection:

FS-B-2X from Tyco Thermal Controls N.V. requires thermostat with temperature sensor, UTR15

Max. heating circuit length in relation to a cut-in temperature of 12 °C (HWAT) or 0 °C (FS-B-2X)		
Heating strip type	Fuse	Length Lmax
HWAT-R	13 A	60 m
	16 A	80 m
	20 A	100 m
FS-B-2X	10 A	65 m
	16 A	105 m

Fuse protection using automatic cutouts with characteristic C

2. Joint

$L \leq L_{max}^*$
Through connection

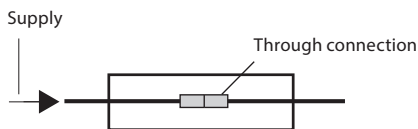

$L \leq L_{max}^*$
Separation of heating strip

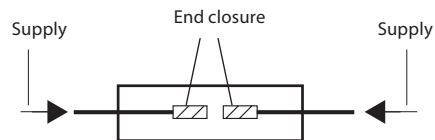

3. T-branch

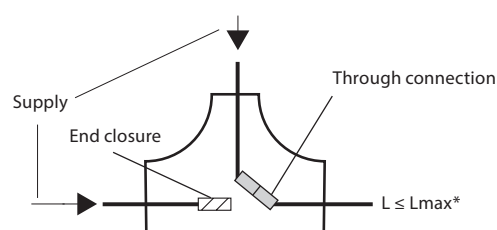
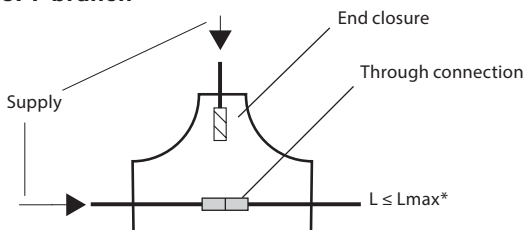

For the T-branch, note that the sum of two connected pipes must not be $> L_{max}^*$. T-switches **cannot** be supplied.

* L_{max} = max. permitted length for heating strip

The heating strip and the accessories are installed by the electrician!

House entry bend 90°

CALPEX PUR-KING UNO (Heating 6 bar)

Bend 90°, delivered without press fittings

Dimensions: CPX 25/76 - 125/182*
CPX 160/250**

Bend 90°, with welded-on press fittings

Dimensions: CPX 140/202 - Carrier pipe P235

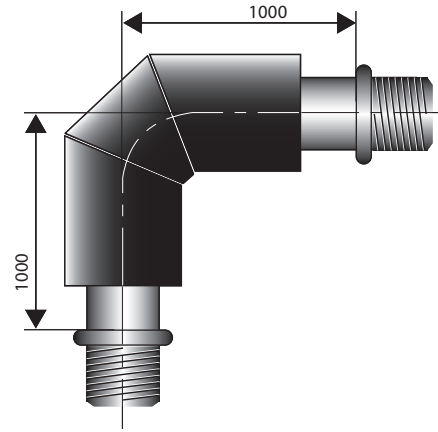
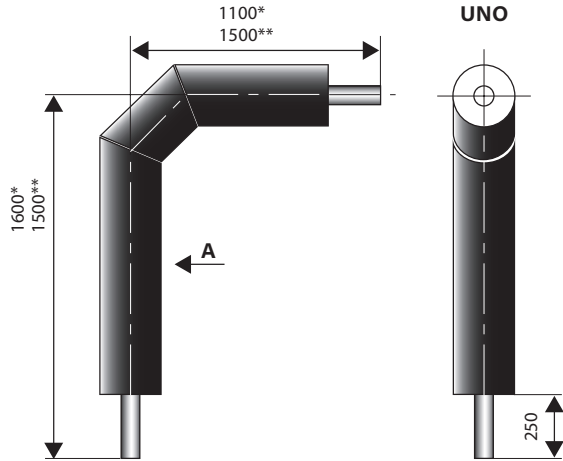

Figures in mm

CALPEX PUR-KING UNO

Type	PEX carrier pipe d x s mm	Outer casing D x s1 mm	Volume carrier pipe l/m	Weight kg/unit
25/ 76	25 x 2.3	75 x 2.9	0.327	2.30
25/ 91 PLUS	25 x 2.3	90 x 3.5	0.327	-
32/ 76	32 x 2.9	75 x 2.9	0.539	2.50
32/ 91 PLUS	32 x 2.9	90 x 3.5	0.539	-
40/ 91	40 x 3.7	90 x 3.5	0.835	3.47
40/111 PLUS	40 x 3.7	110 x 4.3	0.835	-
50/111	50 x 4.6	110 x 4.3	1.307	4.92
50/126 PLUS	50 x 4.6	125 x 4.9	1.307	-
63/126	63 x 5.8	125 x 4.9	2.075	6.50
63/142 PLUS	63 x 5.8	140 x 4.4	2.075	-
75/142	75 x 6.8	140 x 4.4	2.961	8.47
75/162 PLUS	75 x 6.8	160 x 5.0	2.961	-
90/162	90 x 8.2	160 x 5.0	4.254	11.40
90/182 PLUS	90 x 8.2	180 x 5.6	4.254	-
110/162	110 x 10.0	160 x 5.0	6.362	14.23
110/182	110 x 10.0	180 x 5.6	6.362	16.19
110/202 PLUS	110 x 10.0	200 x 6.2	6.362	-
125/182	125 x 11.4	180 x 5.6	8.203	17.20
125/202 PLUS	125 x 11.4	200 x 6.2	8.203	-
140/225	140 x 12.7	225 x 6.9	10.315	40.95
160/250	160 x 14.6	250 x 6.2	13.437	58.40

Connection with press connections (for coupling, see CPX 1.390)

Supplementary insulation ≤ Ø 182 mm with CPX clip shells (for CPX-I shell, see CPX 1.325/1.326)
or ≥ Ø 202 mm with shrink-on sleeves (see CPX 1.320)

House entry bend 90°

CALPEX PUR-KING DUO (Heating 6 bar)

Bend 90°, delivered without press fittings

Dimensions: CPX 25/25/91 - 75+75/202

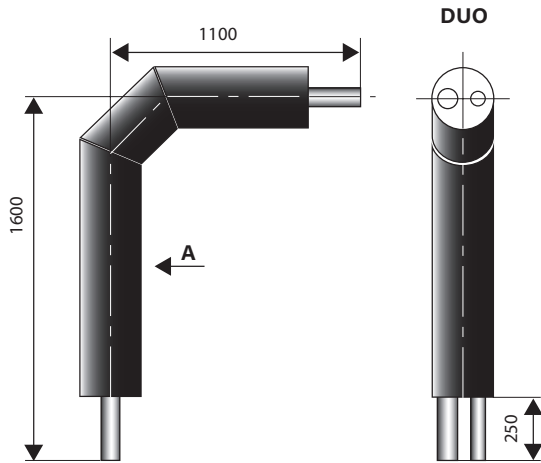

Figures in mm

CALPEX PUR-KING DUO

Type	PEX carrier pipe d x s mm	Outer casing D x s1 mm	Volume carrier pipe l/m	Weight kg/unit
25 + 25/ 91	2 x 25 x 2.3	90 x 3.5	2 x 0.327	4.32
25 + 25/111 PLUS	2 x 25 x 2.3	110 x 4.3	2 x 0.327	-
32 + 32/111	2 x 32 x 2.9	110 x 4.3	2 x 0.539	4.67
32 + 32/126 PLUS	2 x 32 x 2.9	125 x 4.9	2 x 0.539	-
40 + 40/126	2 x 40 x 3.7	125 x 4.9	2 x 0.835	7.42
40 + 40/142 PLUS	2 x 40 x 3.7	140 x 4.3	2 x 0.835	-
50 + 50/162	2 x 50 x 4.6	160 x 5.0	2 x 1.307	9.90
50 + 50/182 PLUS	2 x 50 x 4.6	180 x 5.6	2 x 1.307	-
63 + 63/182	2 x 63 x 5.8	180 x 5.6	2 x 2.075	13.96
63 + 63/202 PLUS	2 x 63 x 5.8	200 x 6.2	2 x 2.075	-
75 + 75/202	2 x 75 x 6.8	200 x 6.2	2 x 2.961	-

Connection with press connections (for coupling, see CPX 1.390)

Supplementary insulation $\leq \varnothing 182$ mm with CPX clip shells (for CPX-I shell, see CPX 1.325/1.326)

or $\geq \varnothing 202$ mm with shrink-on sleeves (see CPX 1.320)

House entry bend 90°

CALPEX SANITARY UNO/DUO (Sanitary 10 bar)

Bend 90°, delivered without press fittings

Dimensions: CPX 20/76 - 63/126

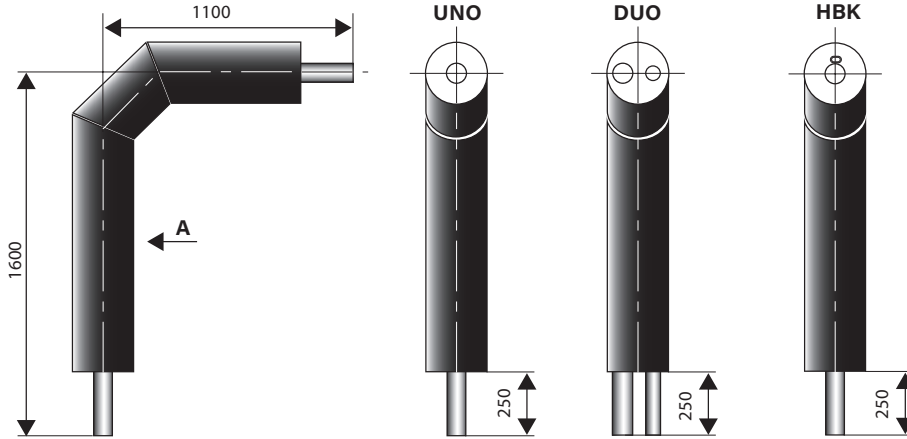

Figures in mm

CALPEX SANITARY UNO

Type	DN	Inches	PEX carrier pipe d x s mm	Outer casing D x s1 mm	Volume carrier pipe l/m	Weight kg/unit
20/ 76	16	5/8	20 x 2.8	75 x 2.9	0.163	2.40
25/ 76	20	3/4	25 x 3.5	75 x 2.9	0.254	2.65
32/ 76	25	1	32 x 4.4	75 x 2.9	0.423	2.80
40/ 91	32	1 1/4	40 x 5.5	90 x 3.5	0.661	3.90
50/111	40	1 1/2	50 x 6.9	110 x 4.3	1.029	5.62
63/126	50	2	63 x 8.7	125 x 4.9	1.633	7.65
32/111 HBK	25	1	32 x 4.4	110 x 4.3	0.423	6.53
50/126 HBK	40	1 1/2	50 x 6.9	125 x 4.9	1.029	9.38

CALPEX SANITARY DUO

Type	DN	Inches	PEX carrier pipe d x s mm	Outer casing D x s1 mm	Volume carrier pipe l/m	Weight kg/unit
25 + 20/ 91	20 + 16	3/4 + 5/8	25.0 x 3.5 + 20.0 x 2.8	90 x 3.5	0.254 + 0.163	3.67
32 + 20/111	25 + 16	1 + 5/8	32.0 x 4.4 + 20.0 x 2.8	110 x 4.3	0.423 + 0.163	4.87
40 + 25/126	32 + 20	1 1/4 + 3/4	40.0 x 5.5 + 25.0 x 3.5	125 x 4.9	0.661 + 0.254	6.50
50 + 32/126	40 + 25	1 1/2 + 1	50.0 x 6.9 + 32.0 x 4.4	125 x 4.9	1.029 + 0.423	7.30

Connection with press connections (for coupling, see CPX 1.390)

Supplementary insulation with CPX clip shells (for CPX-I shell, see CPX 1.325/1.326)

or with shrink-on sleeves (see CPX 1.320)

House entry bend 90°

CALPEX QUADRIGA (Heating 6 bar, Sanitary 10 bar)

Bend 90°, DN 16 - DN 32

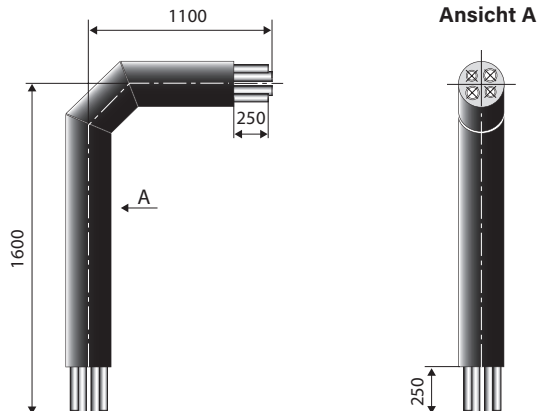

Figures in mm

CALPEX QUADRIGA

Type	DN	Inches	PEX carrier pipe d x s mm	Outer casing D x s1 mm	Volume carrier pipe l/m	Weight kg/unit
H25 + 25/S25 + 20/142	20	¾	25 x 2.3	140 x 4.4	0.327	8.12
	20	¾	25 x 2.3		0.327	
	20	¾	25 x 3.5		0.254	
	16	5/8	20 x 2.8		0.163	
H32 + 32/S25 + 20/142	25	1	32 x 2.9	140 x 4.4	0.539	8.47
	25	1	32 x 2.9		0.539	
	20	¾	25 x 3.5		0.254	
	16	5/8	20 x 2.8		0.163	
H32 + 32/S32 + 20/142	25	1	32 x 2.9	140 x 4.4	0.539	8.52
	25	1	32 x 2.9		0.539	
	25	1	32 x 4.4		0.423	
	16	5/8	20 x 2.8		0.163	
H40 + 40/S40 + 25/162	32	1¼	40 x 3.7	160 x 5.0	0.835	10.37
	32	1¼	40 x 3.7		0.835	
	32	1¼	40 x 5.5		0.661	
	20	¾	25 x 3.5		0.254	

Connection with press connections (for coupling, see CPX 1.390)

Supplementary insulation with shrink-on sleeves (see CPX 1.320)

CALPEX L-shell

Dimensions Ø 76 - 126 mm

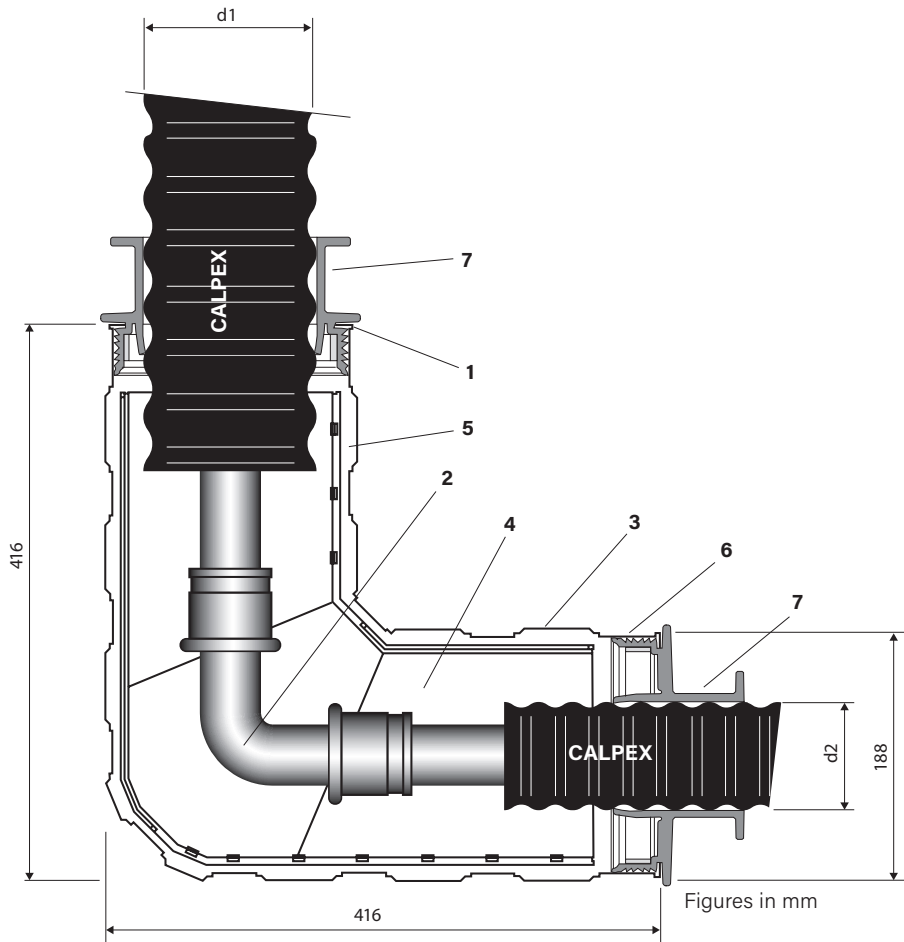

CALPEX L-shell, UNO/DUO

Outer casing Ø d1	Ø d2			
	76	91	111	126
76		x		
91			x	
111			x	
126				x

Note: CALPEX shells are not suggested to be installed UV exposed!

CALPEX shells are not suitable for use with CALPEX QUADRIGA (distribution chamber: see CPX 1.350).

Structure of the half-shell

- 1 ABS half-shells
- 2 PEX angle coupling;
see CPX 1.390
- 3 Sealing clamps (15 pcs.)
- 4 Insulation material;
see CPX 1.365
- 5 Glued surface
- 6 Reduction ring or sealing ring
- 7 Hose clip

CALPEX Big L-shell

Dimensions Ø 142 - 202 mm

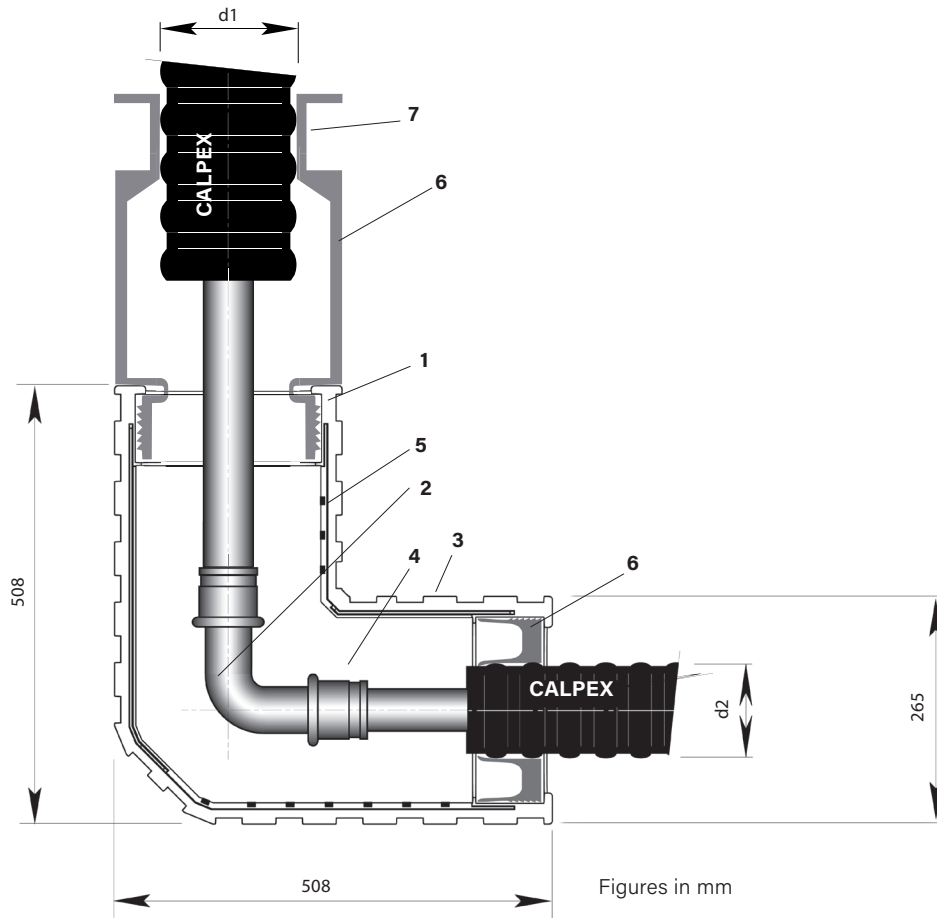

CALPEX Big L-shell, UNO/DUO

Outer casing Ø d1	Ø d2			
	142	162	182	202
142	x			
162		x		
182			x	
202				x

Structure of the half-shell

- 1 ABS half-shells
- 2 PEX angle coupling;
see CPX 1.390
- 3 Sealing clamps (22 pcs.)
- 4 Insulation material;
see CPX 1.365
- 5 Glued surface
- 6 Reduction ring or sealing ring
- 7 Hose clip

Note: CALPEX shells are not suggested to be installed UV exposed!

CALPEX shells are not suitable for use with CALPEX QUADRIGA (distribution chamber: see CPX 1.350).
CALPEX Big-shells are freely reducible from Ø 202 mm to Ø 76 mm

Joint using PE-HD shrink sleeve

Dimensions Ø 76 - 250 mm

CALPEX joint

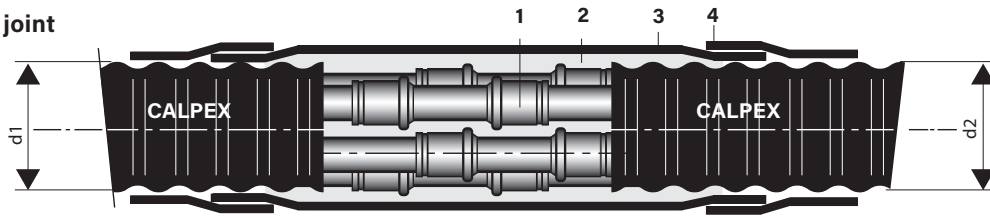

CALPEX reduction joint

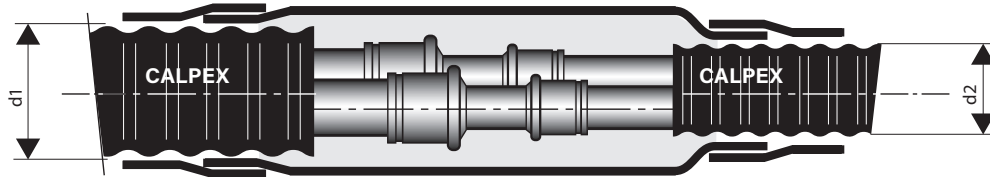

CALPEX - Insulated steel pipe

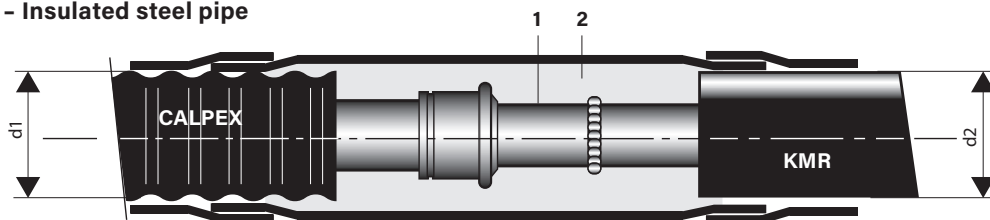

- 1 PEX coupling; see sheet 1.390
- 2 Insulation material, PUR or PE; see sheet 1.365
- 3 Shrink sleeve pipe
- 4 Shrink hose

Installation note:

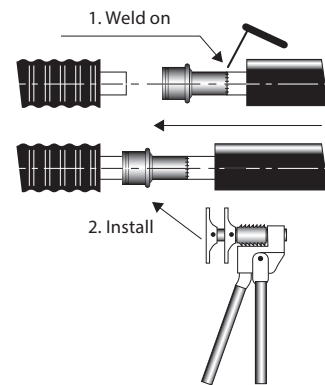

CALPEX-CALPEX

	Ø d2	76	91	111	126	142	162	182	202	250
Ø d1	76	x	x							
	91		x	x						
	111			x	x					
	126				x	x				
	142					x	x			
	162						x	x		
	182							x	x	
	202								x	x
	250									x

CALPEX to insulated steel pipe

	Ø d2	90	110	125	140	160	180	200	225	250	280	315	
Ø d1	76	x	x	x									
	91	x	x	x	x								
	111	x	x	x	x								
	126		x	x	x	x							
	142			x	x	x	x						
	162				x	x	x	x	x	x			
	182				x	x	x	x	x	x			
	202						x	x	x				
	250										x	x	x

CALPEX I-shell

Dimensions Ø 76 - 126 mm

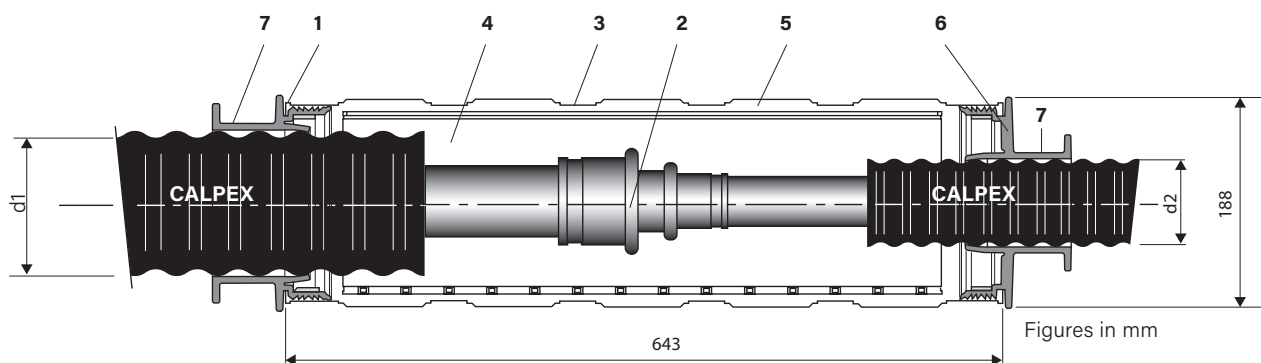

CALPEX I-shell, UNO/DUO

Outer casing Ø d1	Ø d2			
	76	91	111	126
76	x			
91	x	x		
111	x	x	x	
126	x	x	x	x

Structure of the half-shell

- 1 ABS half-shells
- 2 PEX coupling; see CPX 1.390
- 3 Sealing clamps (14 pcs.)
- 4 Insulation material; see CPX 1.365
- 5 Glued surface
- 6 Reduction ring or sealing ring
- 7 Hose clip

Note: CALPEX shells are not suggested to be installed UV exposed!

CALPEX shells are not suitable for use with CALPEX QUADRIGA (distribution chamber: see CPX 1.350).

CALPEX Big I-shell

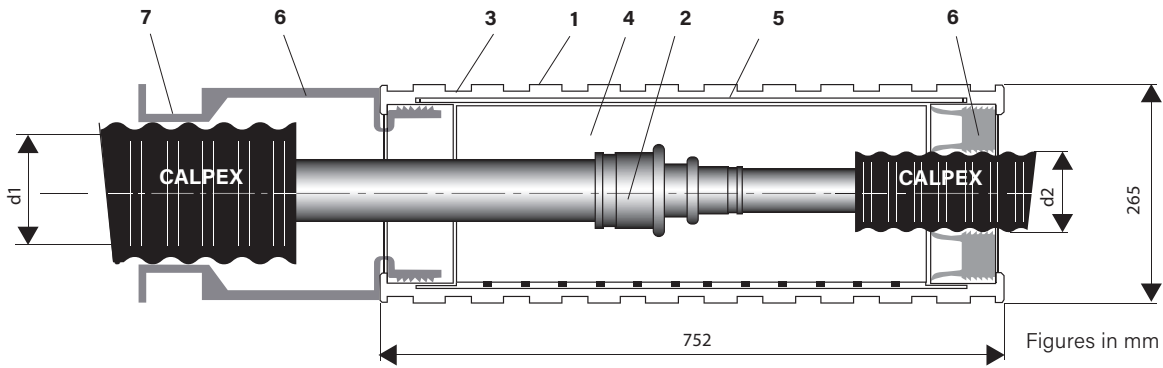

CALPEX Big I-shell, UNO/DUO/QUADRIGA

Outer casing Ø d1	Ø d2			
	142	162	182	202
142	x			
162	x	x		
182	x	x	x	
202	x	x	x	x

Note: CALPEX shells are not suggested to be installed UV exposed!

Distribution chamber: see CPX 1.350

CALPEX Big-shells are freely reducible from Ø 202 mm to Ø 76 mm.

Structure of the half-shell

- 1 ABS half-shells
- 2 PEX coupling; see CPX 1.390
- 3 Sealing clamps (22 pcs.)
- 4 Insulation material; see CPX 1.365
- 5 Glued surface
- 6 Reduction ring or sealing ring
- 7 Hose clip

CALPEX T-shell

Dimensions Ø 76 - 126 mm

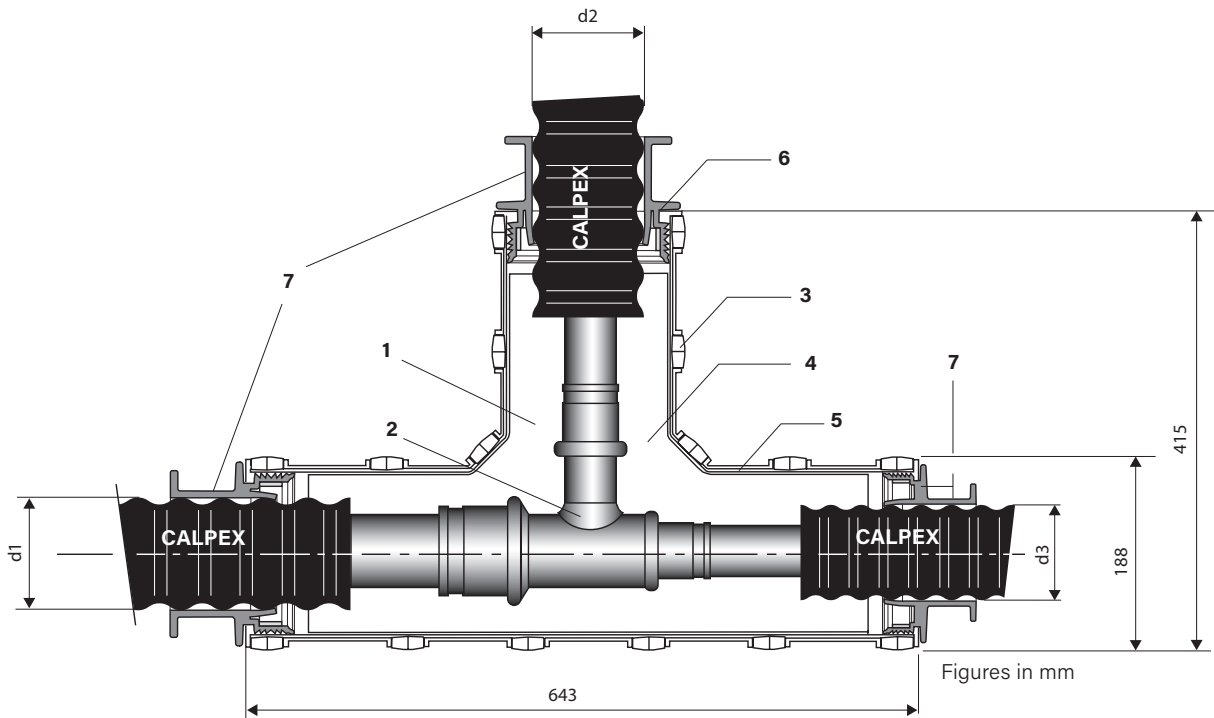

CALPEX T-shell, UNO/DUO

Outer casing Ø d1 - Ø d3	Branch, Ø d2			
	76	91	111	126
76 - 76	x	x	x	x
91 - 91	x	x	x	x
91 - 76	x	x	x	x
111 - 111	x	x	x	x
111 - 91	x	x	x	x
111 - 76	x	x	x	x
126 - 126	x	x	x	x
126 - 111	x	x	x	x
126 - 91	x	x	x	x
126 - 76	x	x	x	x

Structure of the half-shell

- 1 ABS half-shells
- 2 PEX T-piece; see CPX 1.395
- 3 Sealing clamps (20 pcs.)
- 4 Insulation material; see CPX 1.365
- 5 Glued surface
- 6 Reduction ring or sealing ring
- 7 Hose clip

Note: CALPEX shells are not suggested to be installed UV exposed!

CALPEX shells are not suitable for use with CALPEX QUADRIGA (distribution chamber: see CPX 1.350).

CALPEX Big T-shell

Dimensions Ø 76 - 202 mm

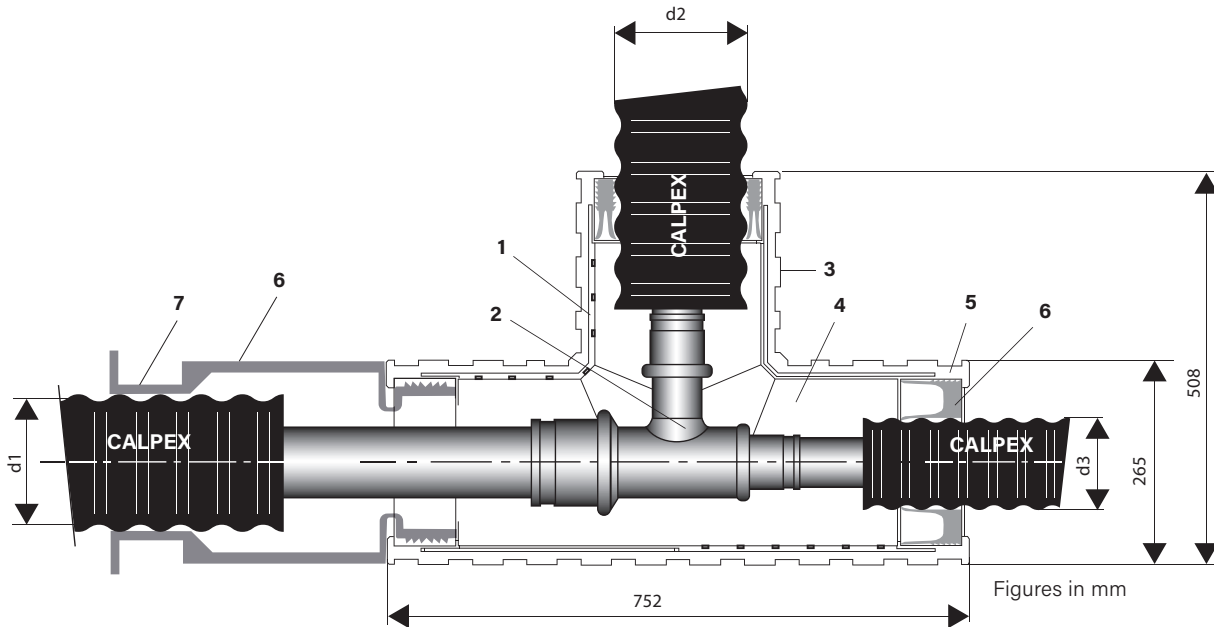

CALPEX Big T-shell, UNO/DUO

Outer casing Ø d1 - Ø d3	Branch, Ø d2							
	76	91	111	126	142	162	182	202
142 - 142	x	x	x	x	x	x	x	x
142 - 126	x	x	x	x	x	x	x	x
142 - 111	x	x	x	x	x	x	x	x
142 - 91	x	x	x	x	x	x	x	x
142 - 76	x	x	x	x	x	x	x	x
162 - 162	x	x	x	x	x	x	x	x
162 - 142	x	x	x	x	x	x	x	x
162 - 126	x	x	x	x	x	x	x	x
162 - 111	x	x	x	x	x	x	x	x
162 - 91	x	x	x	x	x	x	x	x
162 - 76	x	x	x	x	x	x	x	x
182 - 182	x	x	x	x	x	x	x	x
182 - 162	x	x	x	x	x	x	x	x
182 - 142	x	x	x	x	x	x	x	x
182 - 126	x	x	x	x	x	x	x	x
182 - 111	x	x	x	x	x	x	x	x
182 - 91	x	x	x	x	x	x	x	x
182 - 76	x	x	x	x	x	x	x	x
202 - 202	x	x	x	x	x	x	x	x
202 - 182	x	x	x	x	x	x	x	x
202 - 162	x	x	x	x	x	x	x	x
202 - 142	x	x	x	x	x	x	x	x
202 - 126	x	x	x	x	x	x	x	x
202 - 111	x	x	x	x	x	x	x	x
202 - 91	x	x	x	x	x	x	x	x
202 - 76	x	x	x	x	x	x	x	x

Structure of the half-shell

- 1 ABS half-shells
- 2 PEX T-piece; see CPX 1.395
- 3 Sealing clamps (27 pcs.)
- 4 Insulation material; see CPX 1.365
- 5 Glued surface
- 6 Reduction ring or sealing ring
- 7 Hose Clip

Note: CALPEX shells are not suggested to be installed UV exposed!

CALPEX shells are not suitable for use with CALPEX QUADRIGA (distribution chamber: see CPX 1.350).
 CALPEX Big-shells are freely reducible from Ø 202 mm to Ø 76 mm

T-joint

CALPEX PUR-KING 125/225 - 160/250

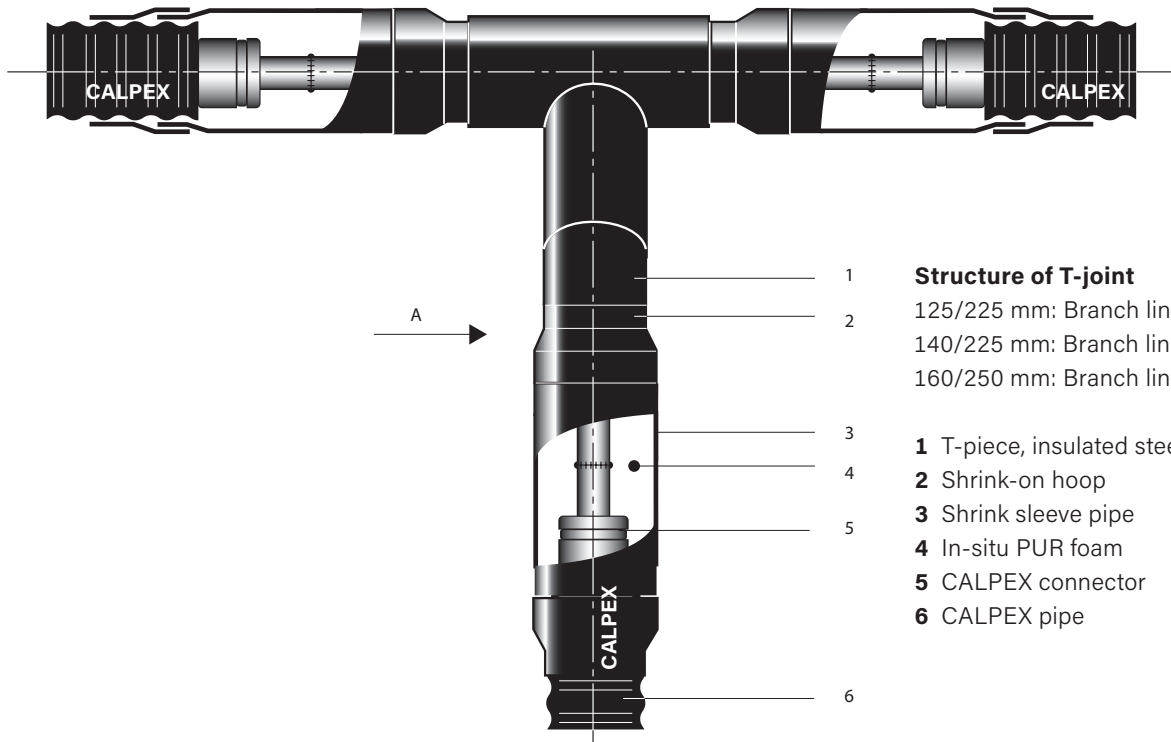

Structure of T-joint

125/225 mm: Branch line, straight
 140/225 mm: Branch line, angled 45°
 160/250 mm: Branch line, angled 45°

- 1 T-piece, insulated steel pipe (St 37.0)
- 2 Shrink-on hoop
- 3 Shrink sleeve pipe
- 4 In-situ PUR foam
- 5 CALPEX connector
- 6 CALPEX pipe

CALPEX UNO (Ø 140, 160 mm)

View A

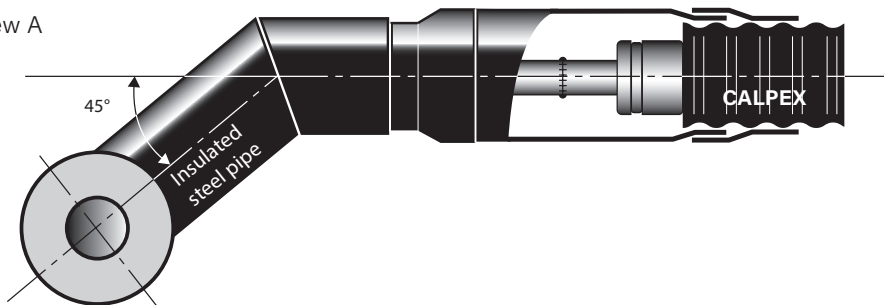

CALPEX UNO (Ø 125 mm) / CALPEX DUO (Ø 75 + 75 mm)

on request

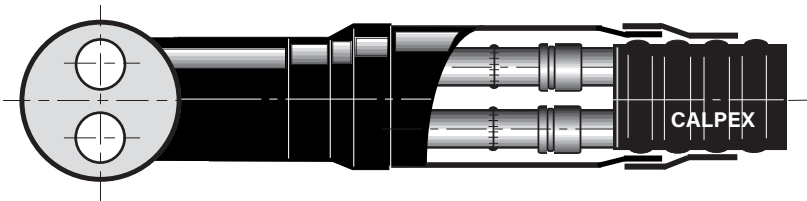

CALPEX T-joint

Outer casing Ø d1 Ø d3	Branch, Ø d2											
	25/76	32/76	40/91	50/111	63/126	75/142	90/162	110/162	110/182	125/182	140/225	160/250
125/225 - 125/225*	x	x	x	x	x	x	x	x	x	x	-	-
140/225 - 140/225*	x	x	x	x	x	x	x	x	x	x	x	-
160/250 - 160/250	x	x	x	x	x	x	x	x	x	x	x	x

* Reduction sockets are required
 We can supply T-pieces with different branches on request for CALPEX-UNO and DUO pipes

Y-pipe

CALPEX PUR-KING (Heating, 6 bar)

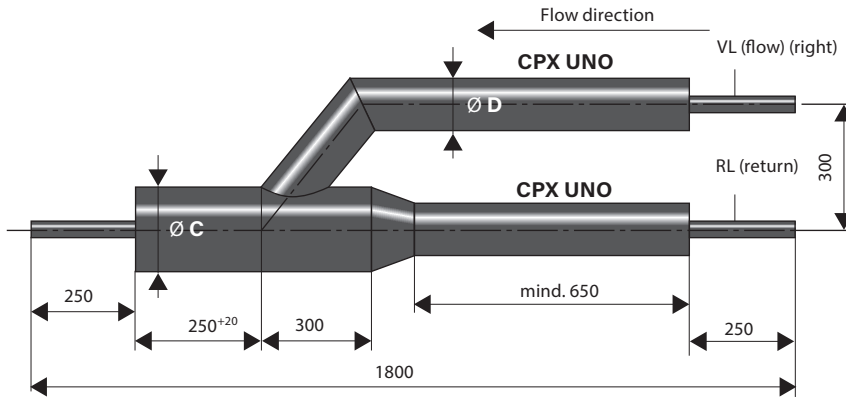

View: A - A

Note: With UNO pipe, in the direction of flow, the forward flow (VL) is always on the right and with DUO pipe, it is always at the bottom.

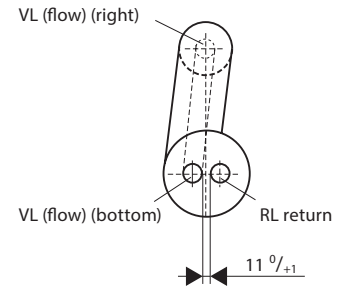

Figures in mm

CALPEX DUO / 2 x CALPEX UNO

UNO pipes mm	Ø D mm	DUO CPX pipe mm	Ø C mm
2 x 25/ 76	75	25 + 25/ 91	90
2 x 25/ 91 PLUS	90	25 + 25/111	110
2 x 32/ 76	75	32 + 32/111	110
2 x 32/ 91 PLUS	90	32 + 32/126	125
2 x 40/ 91	90	40 + 40/126	125
2 x 40/111 PLUS	110	40 + 40/142	140
2 x 50/111	110	50 + 50/162	160
2 x 50/126 PLUS	125	50 + 50/182	180
2 x 63/126	125	63 + 63/182	180
2 x 63/142 PLUS	140	63 + 63/202	200
2 x 75/142	140	75 + 75/202	225*

*Reduction sockets Ø 225/202 are required

PEXa carrier pipe – made of steel on request (P235 TR 1/GH)

Connection with press connections (for coupling, see CPX 1.390)

Supplementary insulation with CPX clip shells (for CPX-I shell, see CPX 1.325/1.326)

or with shrink-on sleeves (see CPX 1.320)

Distribution chamber

Dimensions CPX 25/76 - 125/182

Distribution chamber for all joints

The distribution chamber is used to cover and protect completed BRUGG pipe joints, shut-off valves or junction branches. The distribution chamber is a watertight structure made of polyethylene; its multi-functional design makes it possible to use one chamber type for all pipe dimensions.

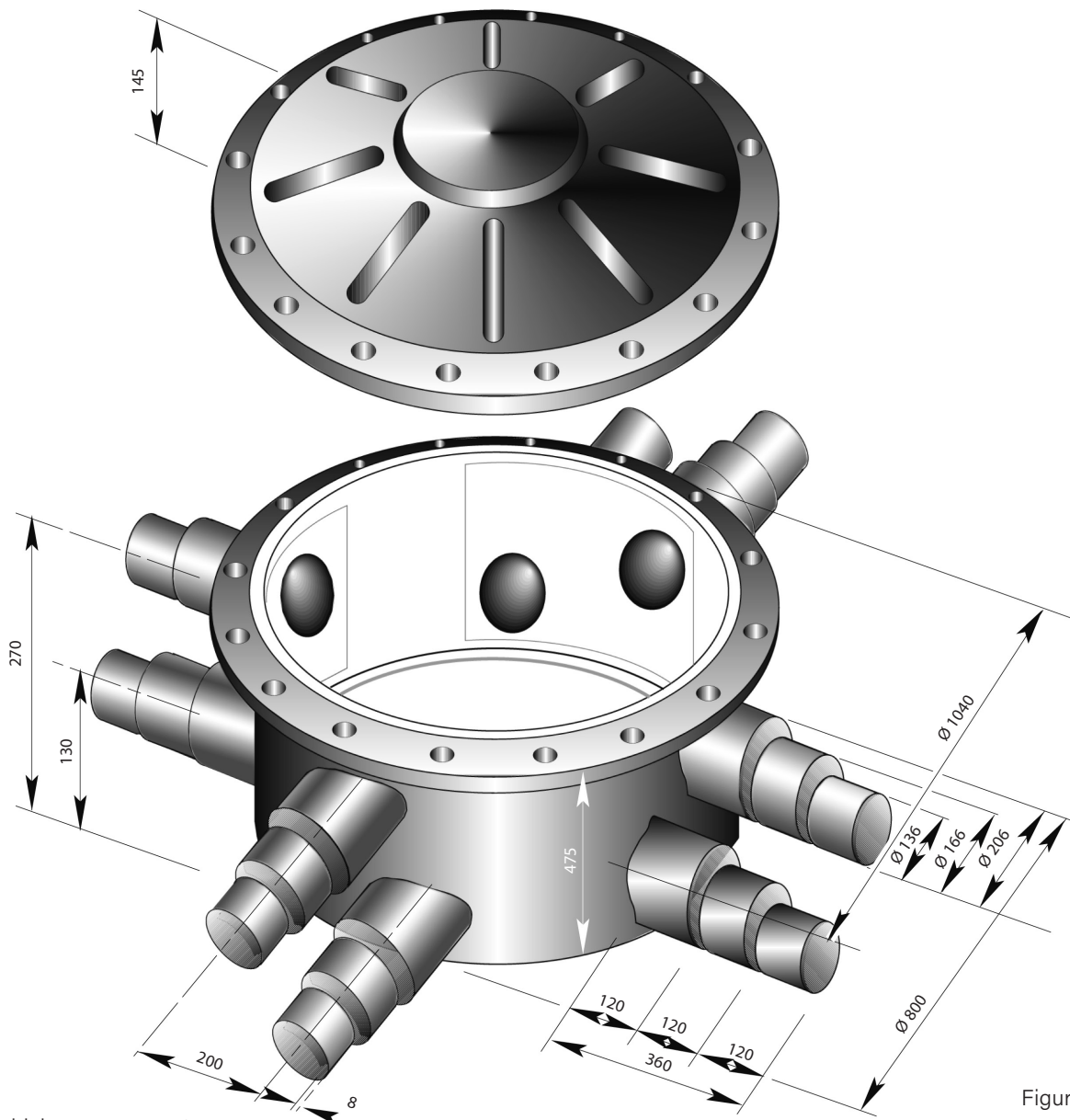

Figures in mm

Wall thickness approx. 8 mm

Ø Chamber exit	Pipe dimensions (outer diameter)	
Ø outer, 206 x 8 mm	Leadthrough for outer Ø	Ø 182, 162*
Ø outer, 166 x 8 mm	Leadthrough for outer Ø	Ø 142, 126*
Ø outer, 136 x 8 mm	Leadthrough for outer Ø	Ø 111, 91*, 76*

* with additional centering ring

Not available in Switzerland

Distribution chamber

Installation for dimensions CPX 25/76 - 125/182

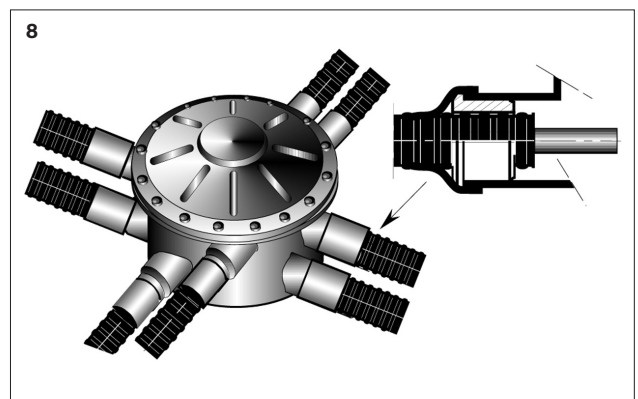
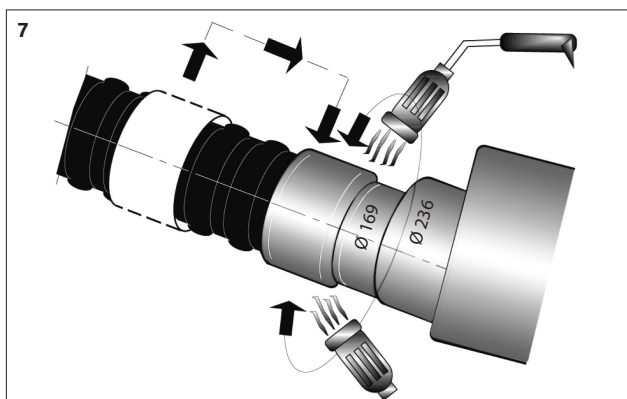
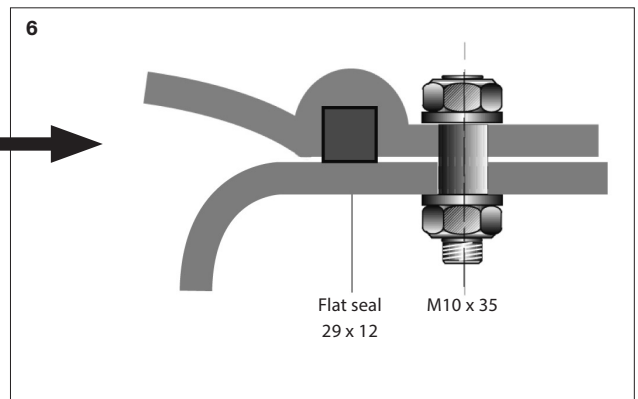
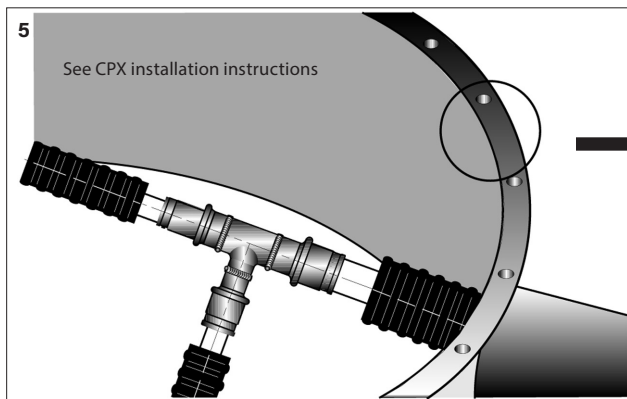
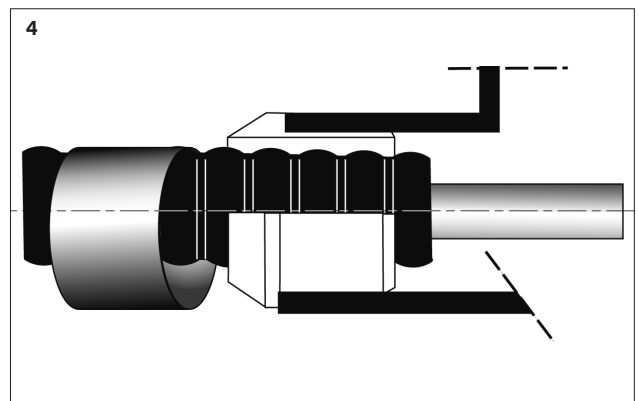
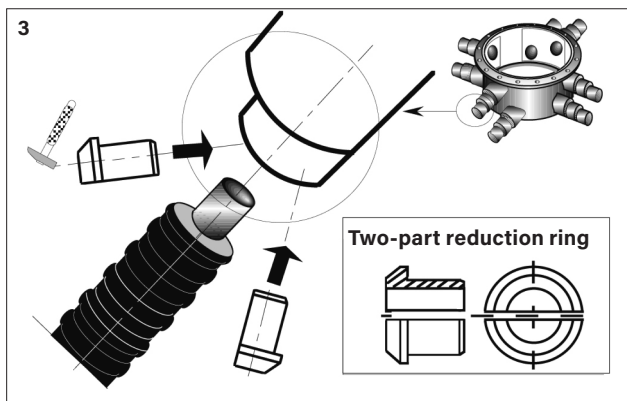
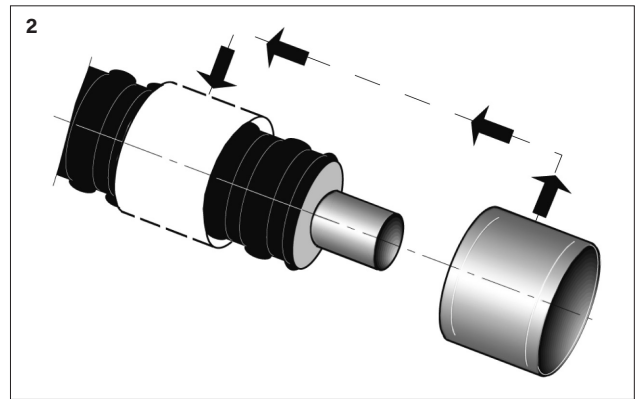
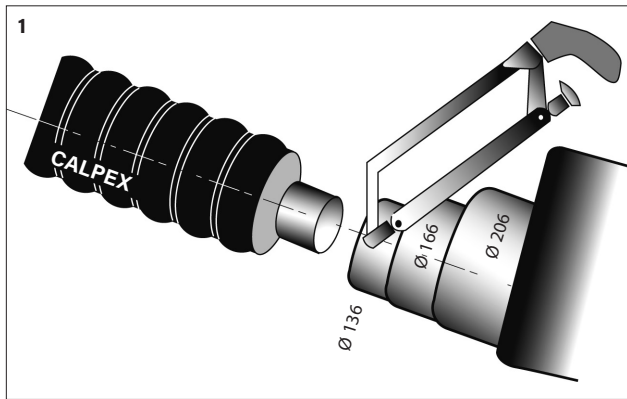

Protective concrete plate

for distribution chamber

Schematic diagram showing installation of cover plate

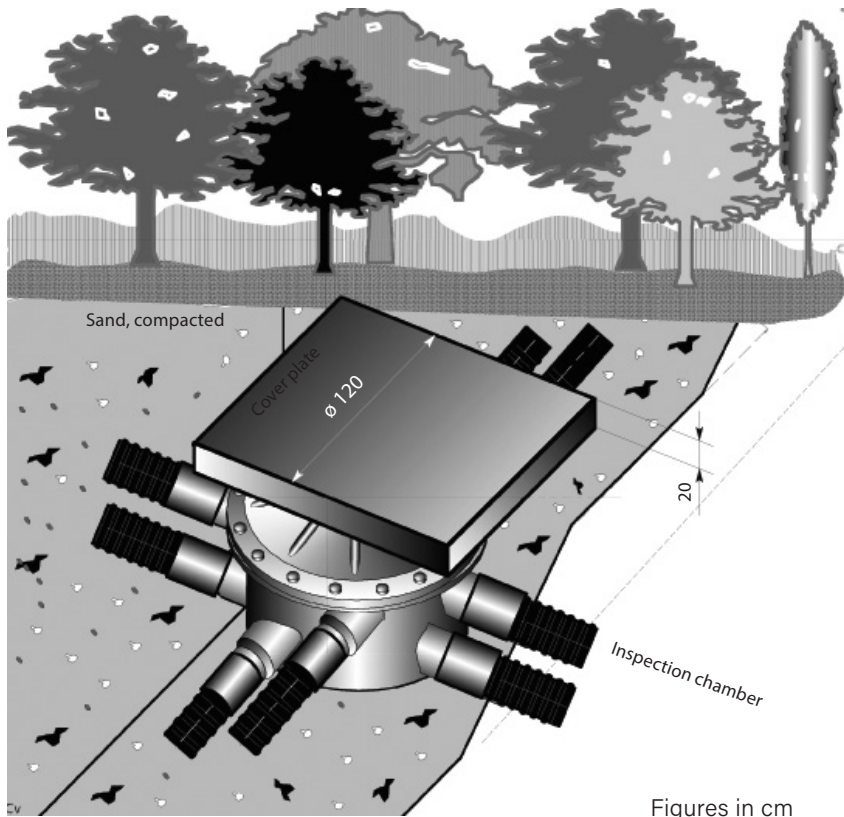

Figures in cm

Load

The cover plate has to be used wherever there might be public traffic and for low-depth installations. The maximum load per unit of area must not exceed

$$q = 153 \text{ kN/m}^2 \text{ (SLW 60 to DIN 1055).}$$

Installation method

Correct installation of the sand must be ensured so that the plate can perform its function as a load shield for the inspection chamber. A Proctor density of $d_{pr} = 96\%$ should be the target for compaction.

For subsequent work on the inspection chamber, the cover plate has lifting eyes. After completing the work and refilling the pit, make sure that the infill between the inspection chamber and concrete slabs is restored correctly.

Filling/insulation material

Some suggestions for filling and insulation materials that can be used are listed below:

- Bulk polystyrene material
- Armaflex or Tubolit
- Foam using BRAG PUR foam canister

Note

There is no need to use filling material in the distribution shaft. Likewise, it is not essential to insulate the pipes! The decision is up to the customer.

Note

The plate must be located so that it completely covers the chamber below (see illustration).

Armouring

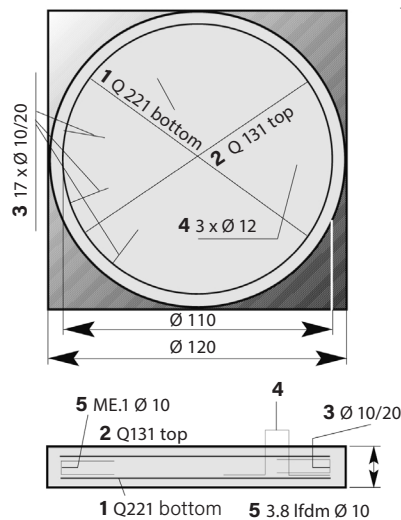

Figures in cm

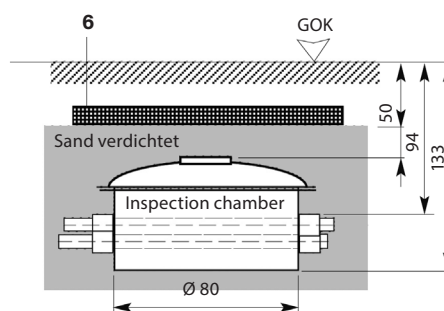

1 Q 221 bottom

2 Q 131 top

3 17 x Ø 10/20 mm (L = 0,5 m) $\begin{matrix} 7.5 \\ 21.5 \end{matrix}$
Total length 8.5 m

4 3 x Ø 12 mm (L = 0.85 m) $\begin{matrix} 12 \\ 21 \\ 16 \\ 15 \end{matrix}$
Total length 2.55 m

Insulation material

PE foam (CPX 25/76 - 110/182), PUR foam container(s)

PUR foam bottles (CPX 25/76 - 160/250)

Insulation material for shrink joints

Polyethylene foam tube, (CPX 25/76 - 110/182)

Extruded pipe insulation made of closed-cell polyethylene, excellent for insulating CALPEX shrink joints (not for CALPEX shells). Various thicknesses of insulation are available for the most common pipe diameters.

The insulation material (thickness and length) is supplied for the relevant joint types. The insulation must be fitted precisely into the joints on site.

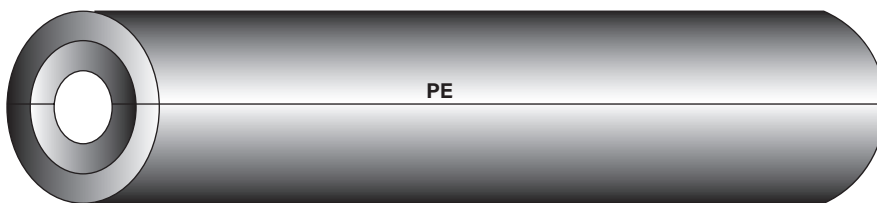

PUR foam for shrink joints and CALPEX shells (CPX 25/76 - 160/250)

CFC-free, cyclopentane-blown PUR foam in plastic bottles

The required quantity of CFC-free polyurethane foam is delivered in suitable container sizes for the various joints and T-pieces. The components are supplied separately in two bottles and are only mixed together when needed. Please note the safety regulations in the installation instructions supplied with the product.



Safety regulations

Protective goggles and gloves must be worn when using this product.

Synthetic gloves

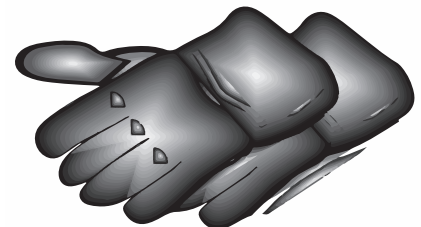

Protective goggles



Screwed connectors

Outer thread, weld end

Connection with external thread

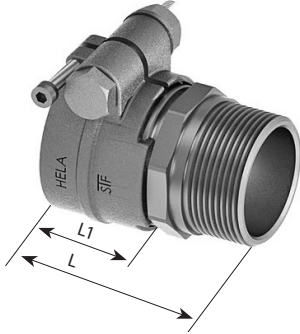

CALPEX PUR-KING (Heating, 6 bar)			CALPEX SANITARY (Sanitary, 10 bar)		
Material: brass			Material: brass		
PEX pipe mm	Screwed connector mm	L/L1 mm	PEX pipe mm	Screwed connector mm	L/L1 mm
25 x 2.3	25 x 2.3-3/4"	61/26	20 x 2.8	20 x 2.8-3/4"	61/26
32 x 2.9	32 x 2.9-1"	68/29	25 x 3.5	25 x 3.5-3/4"	63/29
40 x 3.7	40 x 3.7-1 1/4"	77/36	32 x 4.4	32 x 4.4-1"	68/29
50 x 4.6	50 x 4.6-1 1/2"	79/36	40 x 5.5	40 x 5.5-1 1/4"	79/36
63 x 5.7	63 x 5.7-2"	97/46	50 x 6.9	50 x 6.9-1 1/2"	79/36
75 x 6.8	75 x 6.8-2 1/2"	107/53	63 x 8.7	63 x 8.7-2"	97/46
90 x 8.2	90 x 8.2-3"	119/58	75 x 10.3	75 x 10.3-2 1/2"	101/53
110 x 10.0	110 x 10.0-4"	135/70	90 x 12.3	90 x 12.3-3"	116/58
125 x 11.4	125 x 11.4-5"	144/69	110 x 15.1	110 x 15.1-4"	135/70
140 x 12.7	140 x 12.7-4"	145/70	125 x 17.1	125 x 17.1-5"	136/69
160 x 14.6	160 x 14.6-6"	145/70			

Connection with weld end

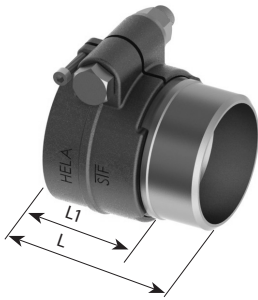

CALPEX PUR-KING (Heating, 6 bar)		
Material: steel		
PEX pipe mm	Weld end mm	L/L1 mm
25 x 2.3	26.9 x 2.3	61/26
32 x 2.9	33.7 x 2.6	63/29
40 x 3.7	42.4 x 2.6	75/36
50 x 4.6	48.3 x 2.6	84/36
63 x 5.7	60.3 x 2.9	88/46
75 x 6.8	76.1 x 2.9	101/53
90 x 8.2	88.9 x 3.2	108/58
110 x 10.0	114.3 x 3.6	114/70
125 x 11.4	114.3 x 3.6	120/69
140 x 12.7	139.7 x 3.6	120/75
160 x 14.6	168.3 x 4.1	145/70

CALPEX PUR-KING (Heating, 10 bar)		
Material: steel		
PEX pipe mm	Weld end mm	L/L1 mm
32 x 4.4	33.7 x 2.6	63/29
40 x 5.5	42.4 x 2.6	75/36
50 x 6.9	48.3 x 2.6	84/36
63 x 8.7	60.3 x 2.9	88/46
75 x 10.3	76.1 x 2.9	101/53
90 x 12.3	88.9 x 3.2	108/58
110 x 15.1	114.3 x 3.6	114/70
125 x 17.1	114.3 x 3.6	120/69

Connections with welded ends must first be welded and then be pressed.

Note: We only recommend using press connections (CPX 1.385 - 1.395) in the soil

Screwed connector

Coupling: equal, elbow 90°

Coupling, equal

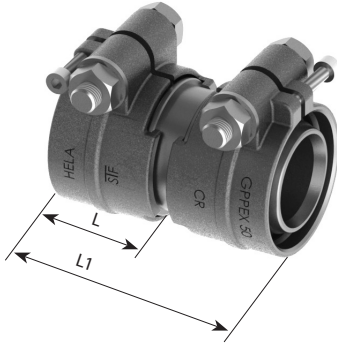

CALPEX PUR-KING (Heating, 6 bar)			CALPEX SANITARY (Sanitary, 10 bar)		
Material: brass			Material: brass		
PEX pipe mm	Coupling mm	L/L1 mm	PEX pipe mm	Coupling mm	L/L1 mm
25 x 2.3	25 x 2.3	68/26	20 x 2.8	20 x 2.8	68/26
32 x 2.9	32 x 2.9	75/29	25 x 3.5	25 x 3.5	72/29
40 x 3.7	40 x 3.7	90/36	32 x 4.4	32 x 4.4	75/29
50 x 4.6	50 x 4.6	90/36	40 x 5.5	40 x 5.5	90/36
63 x 5.7	63 x 5.7	110/46	50 x 6.9	50 x 6.9	90/36
75 x 6.8	75 x 6.8	128/52	63 x 8.7	63 x 8.7	110/46
90 x 8.2	90 x 8.2	144/58	75 x 10.3	75 x 10.3	128/52
110 x 10.0	110 x 10.0	168/70	90 x 12.3	90 x 12.3	144/58
125 x 11.4	125 x 11.4	167/69	110 x 15.1	110 x 15.1	168/70
140 x 12.7	140 x 12.7	-	125 x 17.1	125 x 17.1	167/69
160 x 14.6	160 x 14.6	168/70			

On request reduced couplings (soldered) are available

Elbow 90°



CALPEX PUR-KING (Heating, 6 bar)		CALPEX SANITARY (Sanitary, 10 bar)	
Material: brass soldered		Material: brass soldered	
PEX pipe mm	on PEX pipe mm	PEX pipe mm	on PEX pipe mm
25 x 2.3	25 x 2.3	20 x 2.8	20 x 2.8
32 x 2.9	32 x 2.9	25 x 3.5	25 x 3.5
40 x 3.7	40 x 3.7	32 x 4.4	32 x 4.4
50 x 4.6	50 x 4.6	40 x 5.5	40 x 5.5
63 x 5.7	63 x 5.7	50 x 6.9	50 x 6.9
75 x 6.8	75 x 6.8	63 x 8.7	63 x 8.7
90 x 8.2	90 x 8.2	75 x 10.3	75 x 10.3
110 x 10.0	110 x 10.0	90 x 12.3	90 x 12.3
125 x 11.4	125 x 11.4	110 x 15.1	110 x 15.1
140 x 12.7	140 x 12.7	125 x 17.1	125 x 17.1

Note: We only recommend using press connections (CPX 1.385 - 1.395) in the soil

Elbow 90°, external thread



CALPEX PUR-KING (Heating, 6 bar)		CALPEX SANITARY (Sanitary, 10 bar)	
Material: brass soldered		Material: brass soldered	
PEX pipe mm	External thread Inch	PEX pipe mm	External thread Inch
25 x 2.3	3/4	32 x 4.4	1

Compression connectors

Outer thread, weld end

Connector with external thread

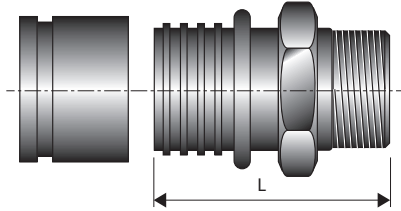

CALPEX PUR-KING (Heating, 6 bar)			CALPEX SANITARY (Sanitary, 10 bar)		
Material: brass			Material: brass		
PEX pipe mm	Screwed connector mm	L mm	PEX pipe mm	Screwed connector mm	L mm
25 x 2.3	25 x 2.3-3/4"	62	20 x 2.8	20 x 2.8- 3/4"	58
32 x 2.9	32 x 2.9-1"	72	25 x 3.5	25 x 3.5-3/4"	62
40 x 3.7	40 x 3.7-1 1/4"	82	32 x 4.4	32 x 4.4-1"	72
50 x 4.6	50 x 4.6-1 1/2"	89	40 x 5.5	40 x 5.5-1 1/4"	82
63 x 5.8	63 x 5.7-2"	109	50 x 6.9	50 x 6.9-1 1/2"	89
75 x 6.8	75 x 6.8-2 1/2"	110	63 x 8.7	63 x 8.7-2"	109
90 x 8.2	90 x 8.2-3"	115			
110 x 10.0	110 x 10.0-4"	120			
125 x 11.4	125 x 11.4-5"	125			
160 x 14.6	160 x 14.6-6"	130			

Connector with weld end

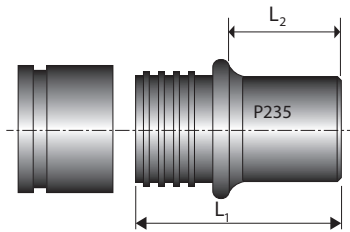

CALPEX PUR-KING (Heating, 6 bar)			
Material: brass			
PEX pipe mm	Weld end mm	L1 mm	L2 mm
25 x 2.3	26.9 x 2.65	50	20
32 x 2.9	33.7 x 2.3	60	24
40 x 3.7	42.4 x 2.6	70	29
50 x 4.6	48.3 x 2.6	85	37
63 x 5.8	60.3 x 2.9	90	32
75 x 6.8	76.1 x 3.2	95	35
90 x 8.2	88.9 x 3.2	95	35
110 x 10.0	114.3 x 3.6	90	30
125 x 11.4	139.7 x 3.6	108	48
140 x 12.7	139.7 x 3.6	112	50
160 x 14.6	168.3 x 4.1	114	50

Connections with welded ends must first be welded and then be pressed.

Press tools see CPX 1.540

Compression connectors

Coupling: equal, coupling: reduced, angle piece: 90°

Coupling

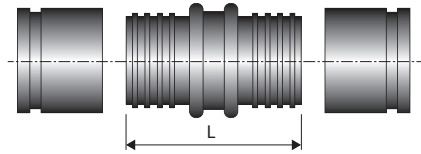

CALPEX PUR (Heating, 6 bar)			CALPEX SANITARY (Sanitary, 10 bar)		
Material: brass			Material: brass		
PEX pipe mm	Coupling mm	L mm	PEX pipe mm	Coupling mm	L mm
25 x 2.3	25 x 2.3	67.0	20 x 2.8	20 x 2.8	58
32 x 2.9	32 x 2.9	88.0	25 x 3.5	25 x 3.5	70
40 x 3.7	40 x 3.7	100.0	32 x 4.4	32 x 4.4	82
50 x 4.6	50 x 4.6	114.0	40 x 5.5	40 x 5.5	90
63 x 5.8	63 x 5.7	141.0	50 x 6.9	50 x 6.9	104
75 x 6.8	75 x 6.8	137.5	63 x 8.7	63 x 8.7	122
90 x 8.2	90 x 8.2	137.5			
110 x 10.0	110 x 10.0	137.5			
125 x 11.4	125 x 11.4	141.0			
140 x 12.7	140 x 12.7	140.0			
160 x 14.6	160 x 14.6	149.0			

Coupling, reduced

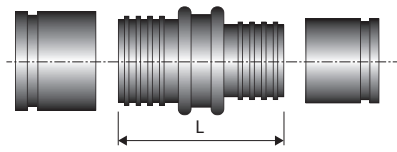

CALPEX PUR-KING (Heating, 6 bar)			CALPEX SANITARY (Sanitary, 10 bar)		
Material: brass/steel* (P235)			Material: brass		
PEX pipe mm	Coupling mm	L mm	PEX pipe mm	Coupling mm	L mm
32 x 2.9	25 x 2.3	80.0	32 x 4.4/25 x 3.5	32 x 4.4/25 x 3.5	76
40 x 3.7	32 x 2.9	100.0	40 x 5.5/32 x 4.4	40 x 5.5/32 x 4.4	86
50 x 4.6	40 x 3.7	108.0	50 x 6.9/40 x 5.5	50 x 6.9/40 x 5.5	97
63 x 5.8	50 x 4.6	129.0	63 x 8.7/50 x 6.9	63 x 8.7/50 x 6.9	113
75 x 6.8	63 x 5.8	138.0			
90 x 8.2	75 x 6.8	142.0			
110 x 10.0	90 x 8.2	142.0			
125 x 11.4*	110 x 10.1	228.0			
140 x 12.7*	125 x 11.4	220.0			
160 x 14.6*	125 x 11.4	262.0			

Angle piece, 90°

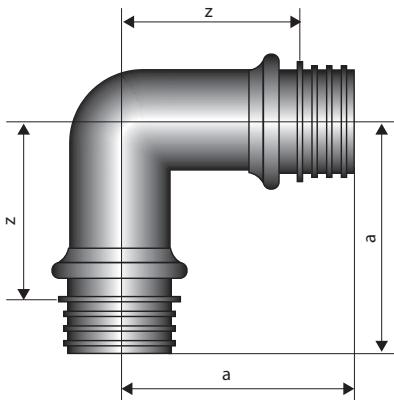

CALPEX PUR-KING (Heating, 6 bar)				CALPEX SANITARY (Sanitary, 10 bar)			
Material: brass/steel* (P235)				Material: brass			
PEX pipe mm	PEX pipe mm	a mm	z mm	PEX pipe mm	PEX pipe mm	a mm	z mm
25 x 2.3	25 x 2.3	54	32	20 x 2.8	20 x 2.8	-	-
32 x 2.9	32 x 2.9	64	37	25 x 3.5	25 x 3.5	-	-
40 x 3.7	40 x 3.7	74	42	32 x 4.4	32 x 4.4	66	39
50 x 4.6	50 x 4.6	87	48	40 x 5.5	40 x 5.5	74	42
63 x 5.8	63 x 5.8	106	60	50 x 6.9	50 x 6.9	87	39
75 x 6.8	75 x 6.8	117	67	63 x 8.6	63 x 8.6	106	60
90 x 8.2	90 x 8.2	127	76				
110 x 10.0	110 x 10.0	137	87				
125 x 11.4*	125 x 11.4	298	260				

Press tools see CPX 1.540

Compression connectors

T-piece

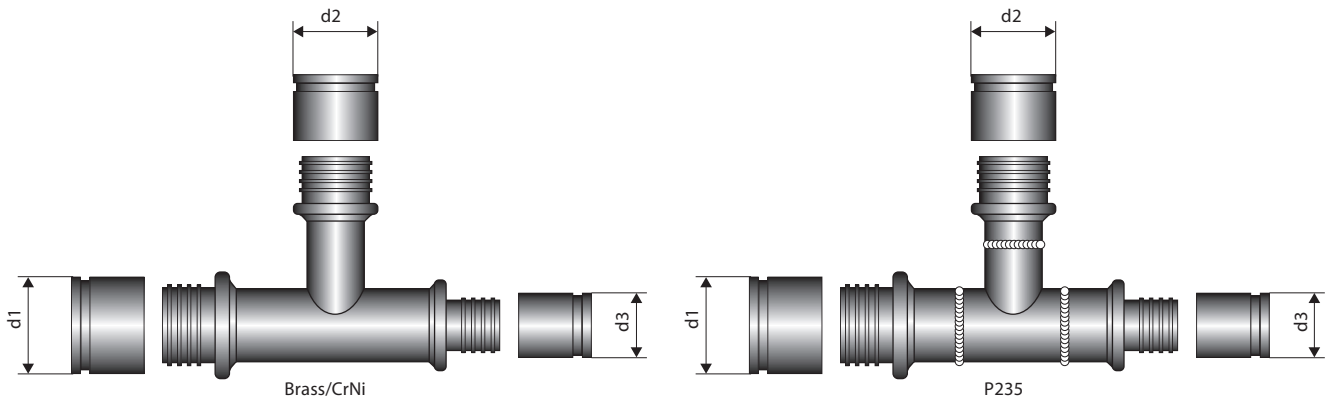

CALPEX PUR-KING (Heating, 6 bar)

ø d1 ø d3 mm	Branch, ø d2								
	mm								
	25 x 2.3	32 x 2.9	40 x 3.7	50 x 4.6	63 x 5.8	75 x 6.8	90 x 8.2	110 x 10.0	125 x 11.4
25 x 2.3 - 25 x 2.3	o/x								
32 x 2.9 - 32 x 2.9	o/x	o/x							
32 x 2.9 - 25 x 2.3	o/x								
40 x 3.7 - 40 x 3.7	o/x	o/x	o/x						
40 x 3.7 - 32 x 2.9	o/x ¹	o/x ¹							
50 x 4.6 - 50 x 4.6	o/x	o/x	o/x	o/x					
50 x 4.6 - 40 x 3.7	o/x	o/x	o/x ¹						
63 x 5.8 - 63 x 5.8	o/x	o/x	o/x	o/x	o/x				
63 x 5.8 - 50 x 4.6	o/+	o/x	o/x	o/x					
75 x 6.8 - 75 x 6.8	o/x	o/x	o/x	o/x	o/x	o/x			
75 x 6.8 - 63 x 5.8	o/+	o/x	o/+	o/x	o/x				
90 x 8.2 - 90 x 8.2	o/+	o/x	o/x	o/+	o/x	o/+	o/x		
90 x 8.2 - 75 x 6.8	o/+	o/+	o/+	o/+	o/+	o/+			
110 x 10.0 - 110 x 10.0	o/+	o/x	o/+	o/x	o/x	o/+	o/+	o/x	
110 x 10.0 - 90 x 8.2	o/+	o/+	o/+	o/+	o/+	o/+	o/+		
125 x 11.4 - 125 x 11.4	o/+	o/+	o/+	o/+	o/+	o/+	o/+	o/+	o/+
125 x 11.4 - 110 x 10.0	o/+	o/+	o/+	o/+	o/+	o/+	o/+	o/+	o/+

¹ Soldered fittings

- T-pieces made of steel can be supplied on request
- Other T-pieces can be supplied on request.
- Dimension DN 150 is supplied in prefabricated and pre-insulated form (see sheet CPX 1.340).

Material:

- x** = Brass CuZn39Pb3 (DN 20 - DN 50), Gunmetal Rg7 (DN 65 - DN 100)
- o** = P235, welded
- +** = CrNi 1.4404, 1.4432, 1.4435 (316L)

T-piece, modular

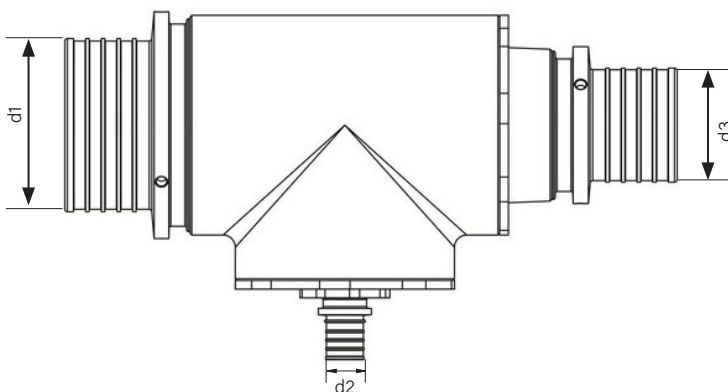

Material:

- Brass CW617N
- Brass bright

Property:

- Modular construction, any combination
- Dimensions 25 - 110 incl. sliding sleeves

Compression connectors

T-piece

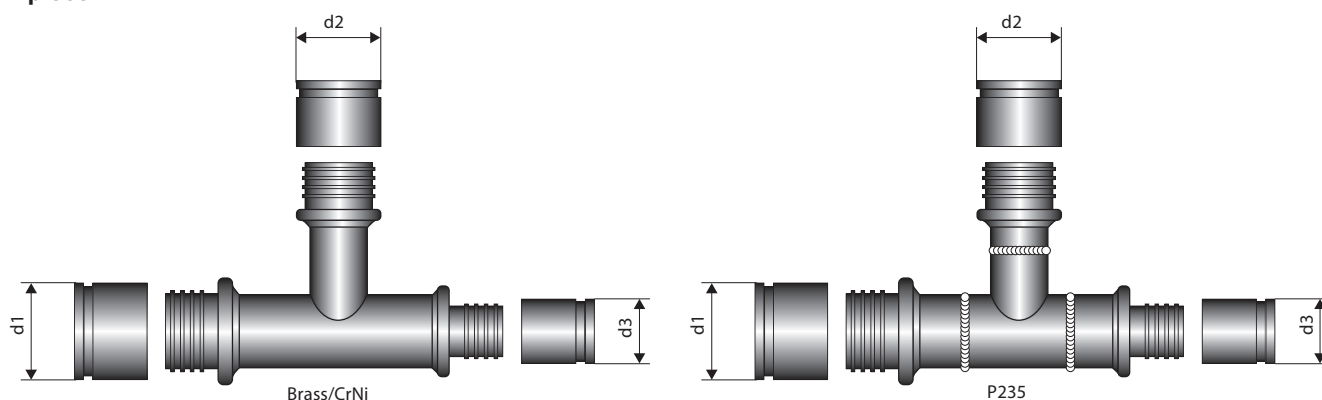

CALPEX SANITARY (Sanitary, 10 bar)

ø d1 ø d3 mm	Branch, ø d2					
	mm					
	20 x 2.8	25 x 3.5	32 x 4.4	40 x 5.5	50 x 6.9	63 x 8,7
20 x 2.8 - 20 x 2.8	x	x				
25 x 3.5 - 25 x 3.5	x	x	x	x		
32 x 4.4 - 32 x 4.4	x	x	x	x		
32 x 4.4 - 25 x 3.5	x	x	x	x		
40 x 5.5 - 40 x 5.5	x	x	x	x	x	
40 x 5.5 - 32 x 3.0	x	x	x	x		
40 x 5.5 - 25 x 3.5	x			x	x	
50 x 6.9 - 50 x 6.9	x	x	x	x	x	
50 x 6.9 - 40 x 5.5	x	x	x	x	x	
50 x 6.9 - 32 x 4.4	x	x	x	x	x	
50 x 6.9 - 25 x 3.5		x		x	x	
63 x 8.7 - 63 x 8.7	x	x	x	x	x	x
63 x 8.7 - 50 x 6.9		x	x	x	x	
63 x 8.7 - 40 x 5.5		x		x	x	x

¹ Soldered fittings

- T-pieces made of steel can be supplied on request
- Other T-pieces can be supplied on request.
- Dimension DN 150 is supplied in prefabricated and pre-insulated form (see sheet CPX 1.340).

Material:

- x** = Brass CuZn39Pb3 (DN 20 - DN 50),
Gunmetal Rg7 (DN 65 - DN 100)
- o** = P235, welded
- +** = CrNi 1.4404, 1.4432, 1.4435 (316L)

Electrofusion joints

Dimensions Ø 75 - 160 mm

Coupling



CALPEX PUR-KING (Heating, 6 bar)

Material: cross-linked polyethylene

PEX pipe mm	PEX pipe mm
50 x 4.6	50 x 4.6
63 x 5.8	63 x 5.8
75 x 6.8	75 x 6.8
90 x 8.2	90 x 8.2
110 x 10.0	110 x 10.0
125 x 11.4	125 x 11.4
140 x 12.7	140 x 12.7
160 x 14.6	160 x 14.6

Angle piece, 90°



CALPEX PUR-KING (Heating, 6 bar)

Material: cross-linked polyethylene

PEX pipe mm	PEX pipe mm
75 x 6.8	75 x 6.8
90 x 8.2	90 x 8.2
110 x 10.0	110 x 10.0
125 x 11.4	125 x 11.4
140 x 12.7	140 x 12.7
160 x 14.6	160 x 14.6

Transition sleeve/joint with flange (AG)



CALPEX PUR-KING (Heating, 6 bar)

Material: cross-linked polyethylene

PEX pipe mm
75 x 6.8
90 x 8.2
110 x 10.0
125 x 11.4

Reduction piece*

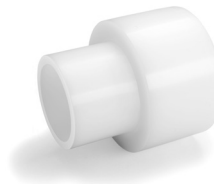

CALPEX PUR-KING (Heating, 6 bar)

Material: cross-linked polyethylene

PEX pipe mm	PEX pipe mm
90	75
110	75
110	90
125	75
125	90
125	110
160	75
160	90
160	110
160	125

T-piece, equal



CALPEX PUR-KING (Heating, 6 bar)

Material: cross-linked polyethylene

PEX pipe mm
50 x 4.6
63 x 5.8
75 x 6.8
90 x 8.2
110 x 10.0
125 x 11.4
140 x 12.7

***Note: Reductions cannot be used when using CALPEX clip shells.**



Leasable basic tool for PEXa electrofusion joints

comprising welding machine and pipe clamps

Article

Tool set without pipe cutter

Additional pipe clamps-set

Pipe cutter 50-125 mm

Pipe cutter 110-160 mm

Only trained personnel, using suitable fusion equipment, may install the electrofusion joints for PEXa connections.

End cap

Standard, shrinkable

Shrink-on end cap, UNO

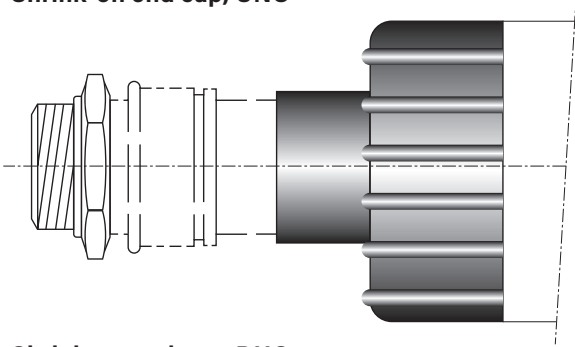

Shrink-on end cap, DUO

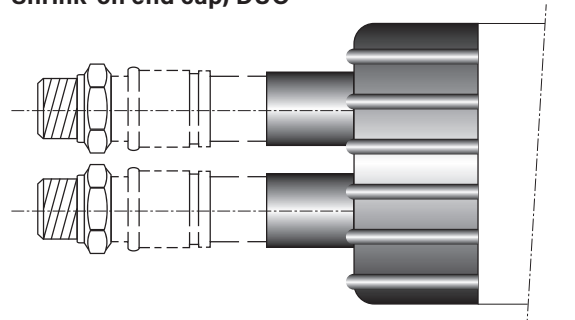

Shrink-on end cap, QUADRIGA

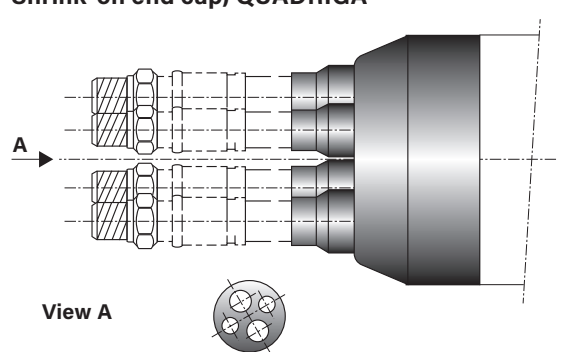

End cap, UNO (LD-PE)

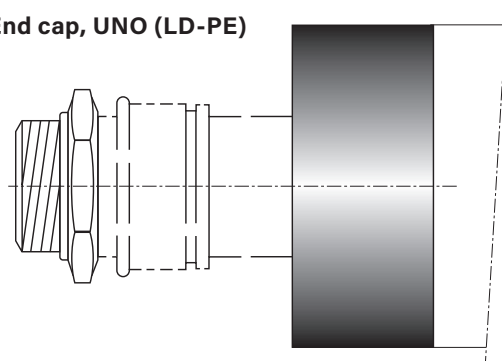

End cap, DUO (LD-PE)

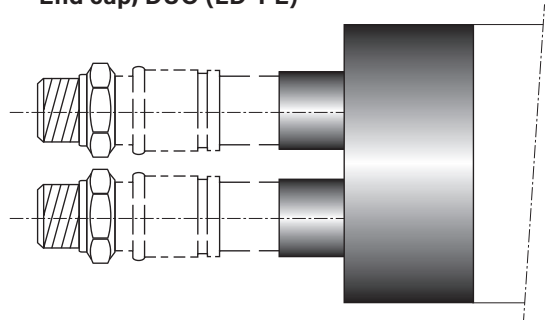

End cap, QUADRIGA (LD-PE)

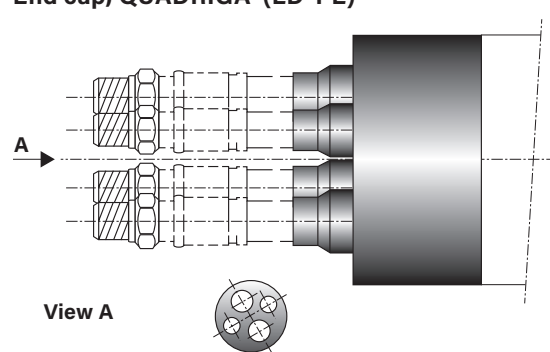

CALPEX UNO	
Type Heating	Type Sanitary
25/ 76	20/ 76
25/ 91 PLUS	25/ 76
32/ 76	32/ 76
32/ 91 PLUS	32/111 HBK
40/ 91	40/ 91
40/111 PLUS	40/126 HBK
50/111	50/111
50/126 PLUS	50/126 HBK
63/126	63/126
63/142 PLUS	
75/142	
75/162 PLUS	
90/162	
90/182 PLUS	
110/162	
110/182	
125/182	
125/202 PLUS	
140/202	
160/250	

CALPEX DUO	
Type	
25 + 20/ 91	
25 + 25/ 91	
25 + 25/111 PLUS	
32 + 20/111	
32 + 32/111	
32 + 32/126 PLUS	
40 + 25/126	
40 + 40/126	
40 + 40/142 PLUS	
50 + 32/126	
50 + 50/162	
50 + 50/182 PLUS	
63 + 63/182	
63 + 63/202 PLUS	
75 + 75/202	

QUADRIGA	
Type	
25 + 25/25 + 20/142	
32 + 32/25 + 20/142	
32 + 32/32 + 20/142	
40 + 40/40 + 25/162	

LD-PE end caps are fitted on;
suitable for dry rooms

Wall sealing ring

for wall openings

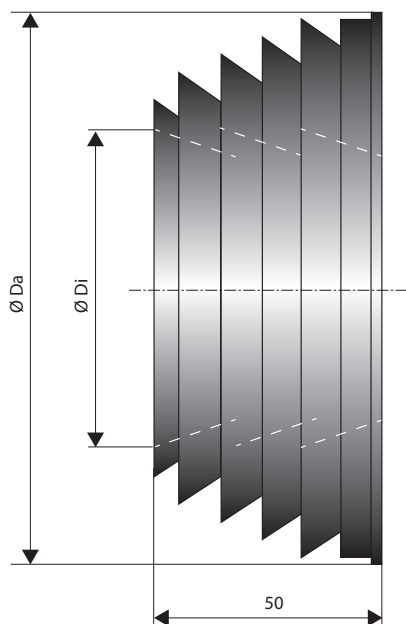

Figures in mm

CALPEX UNO, DUO, QUADRIGA

Outer casing diameter	Neoprene wall sealing ring	
mm	$\varnothing Di$, inner mm	$\varnothing Da$, outer mm
76	74	118
91	88	133
111	107	153
126	122	168
142	137	183
162	155	203
182	175	223
202	195	230
225	180	240
250	243	290

Building entry (see sheet CPX 1.415)

Building entry

Wall opening

Wall leadthrough

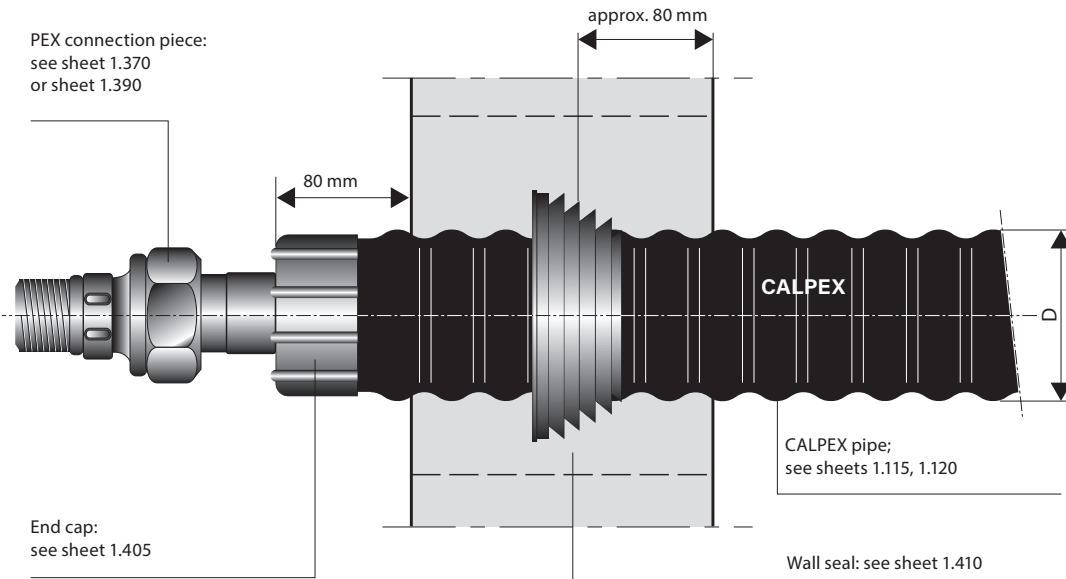

Wall opening

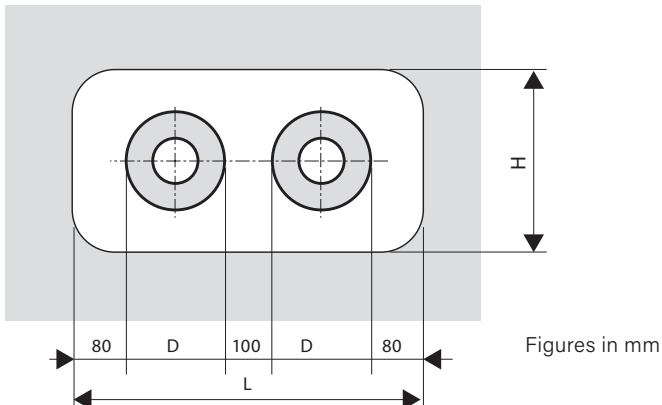

Outer casing Ø D mm	L min mm	H min mm
78	450	250
93	500	250
113	500	300
128	550	300
143	600	350
163	650	350
183	670	380
202	720	400
225	740	400
250	810	450

Core bores

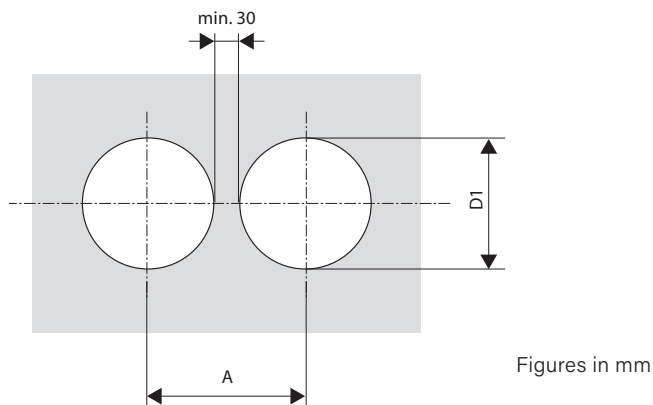

Outer casing Ø D mm	A mm	D1 mm
78	210	180
93	230	180
113	250	220
128	270	230
143	290	230
163	310	280
183	330	280
202	400	350
225	400	350
250	420	380

Wall seal

Core bores/cement liner pipes

Standard

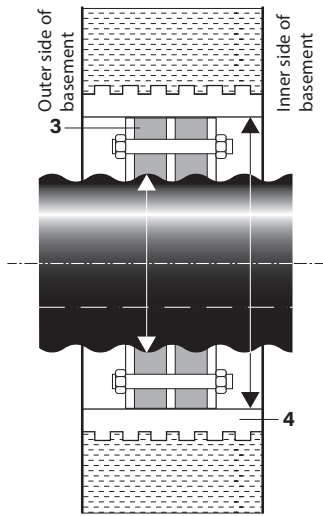

With additional centering ring

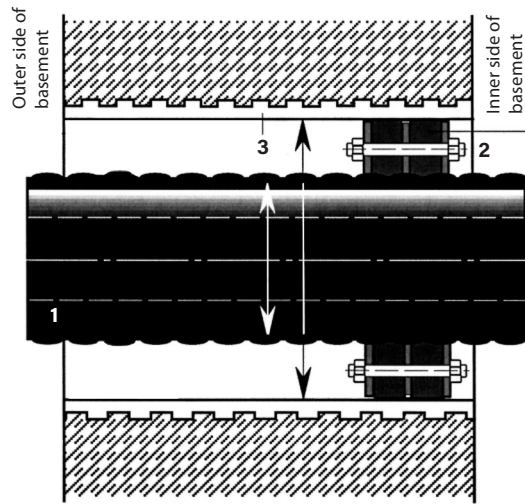

- 1 CALPEX district heating pipe
- 2 Seal set, double-seal* suitable for pressure from water up to 0.5 bar
2 x 40 mm, Shore hardness D 35
- 3 Liner pipe: made of fibre cement or coated core bore

Core bores

Perfect bores are required for installation. As hairline cracks may be present in the concrete or result from drilling, it is advisable to seal the entire length of the borehole with suitable sealant (such as AQUAGARD).

Tightness can only be guaranteed if this recommendation is followed.

Outer pipe Ø R mm	Liner pipe, core bore Ø D mm	Seal set Ø innen mm	Core bore Ø mm
76	150	78 - 85	150
91	150	86 - 94	150
111	200	105 - 115	200
126	200	125 - 135	200
142	200	137 - 145	200
162	250	157 - 165	250
182	250	180 - 190	250
202	300	198 - 207	300
225	300	225 - 233	300
250	350	250 - 259	350

Building entry (see sheet CPX 1.425)

Building entry

Core bores/cement pipe liners

Wall leadthrough

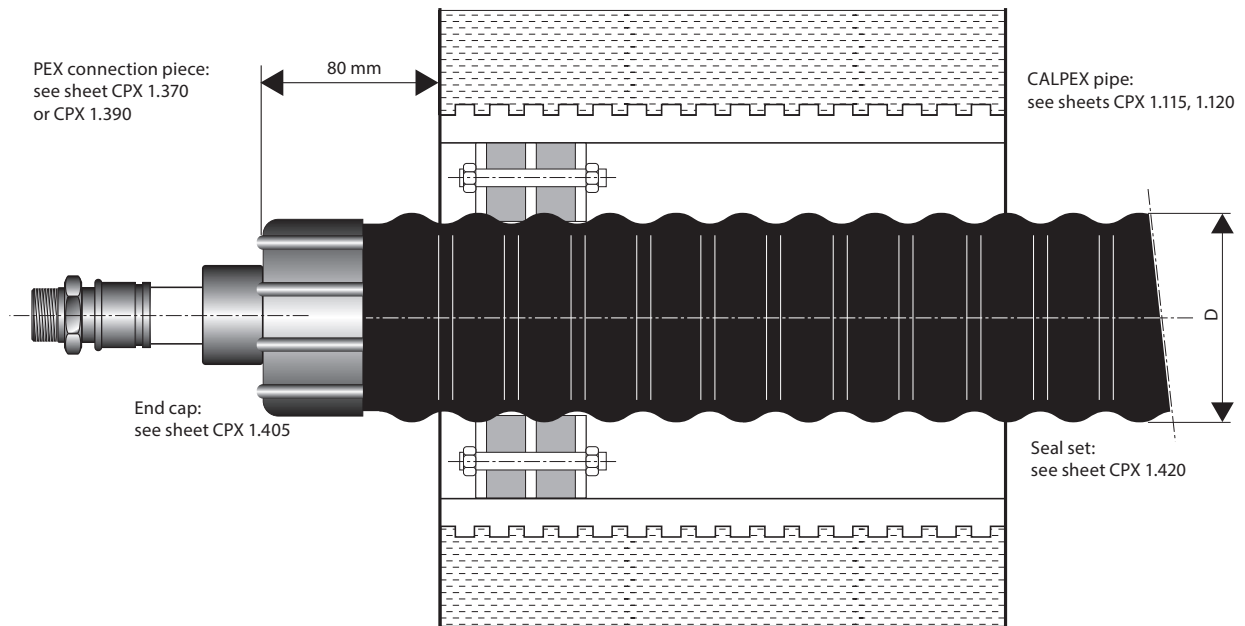

Core bores

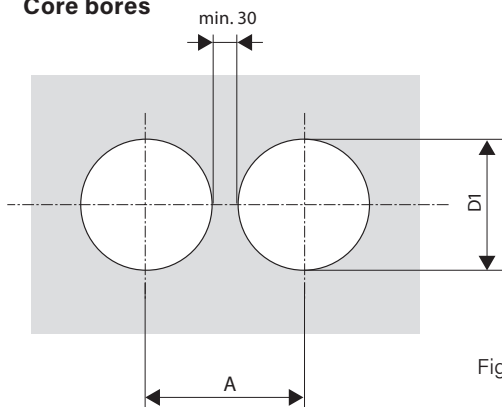

Figures in mm

Outer casing Ø D mm	A mm	D1 mm
78	180	150
93	180	150
113	230	200
128	230	200
143	230	200
163	280	250
183	280	250
202	330	300
225	330	300
250	380	350

Pipe routing

CALPEX - Connection to insulated steel

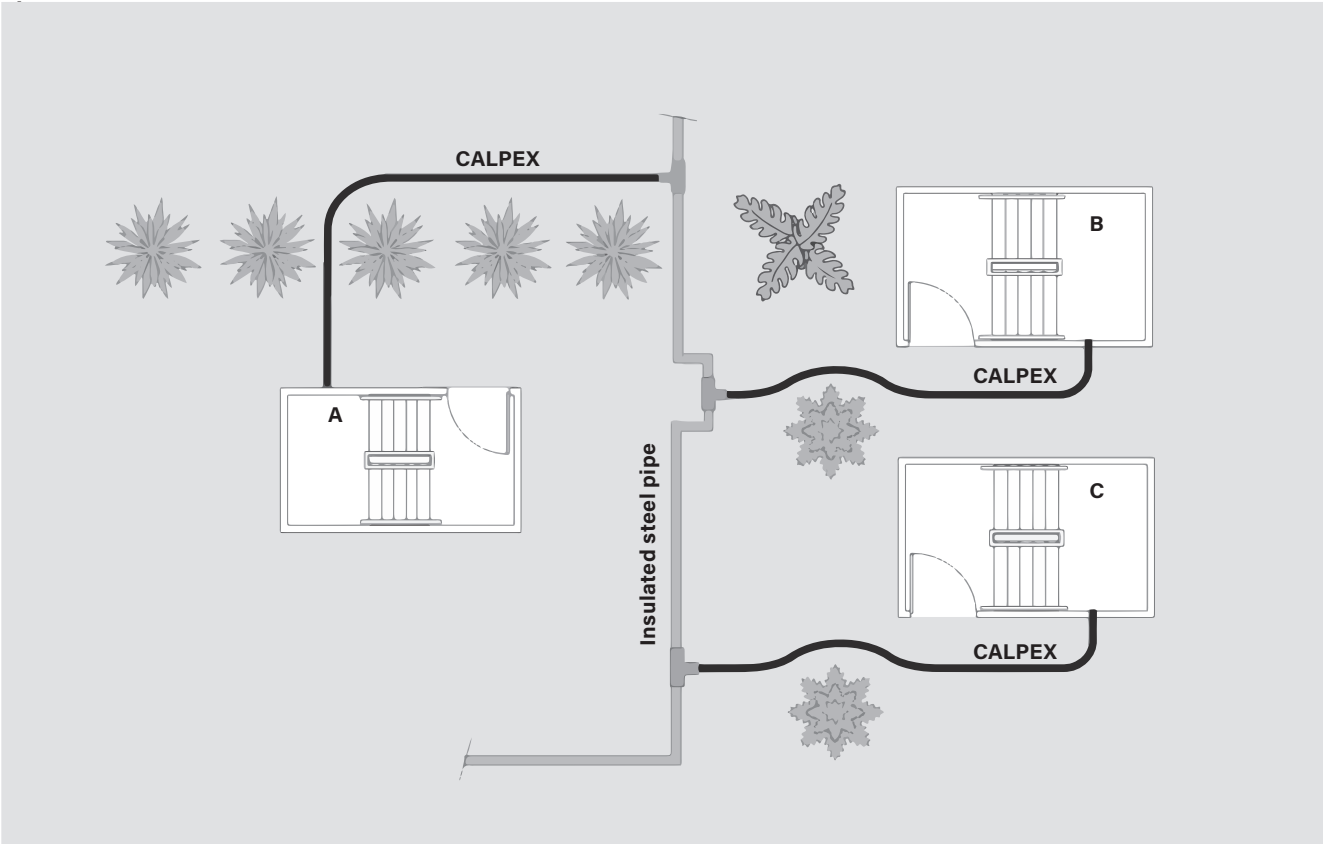

Loop-in method

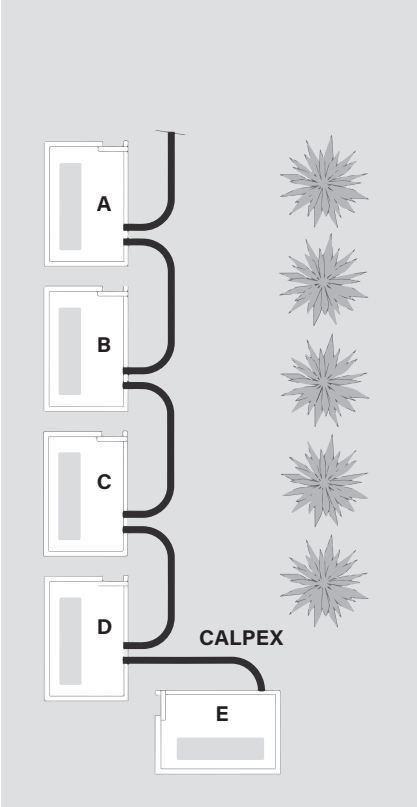

CALPEX - CALPEX connection

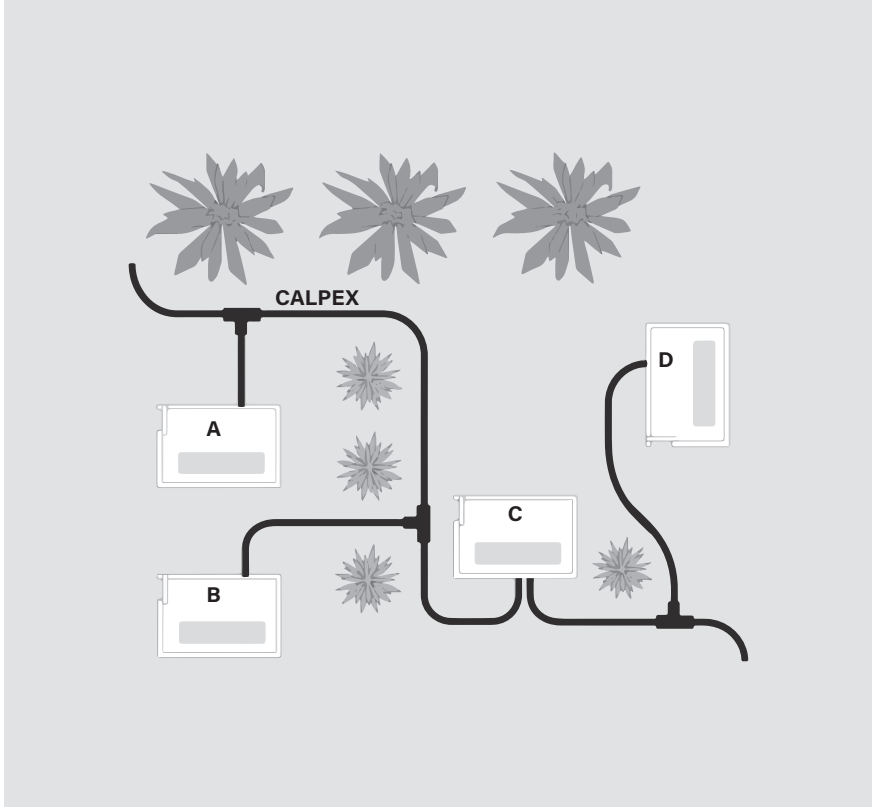

Trench dimensions

Trench profile, 2 CALPEX pipes

UNO

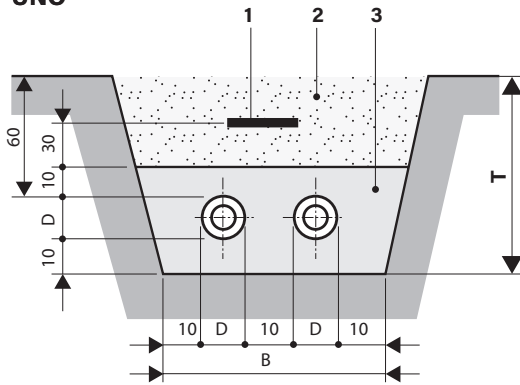

DUO, QUADRIGA

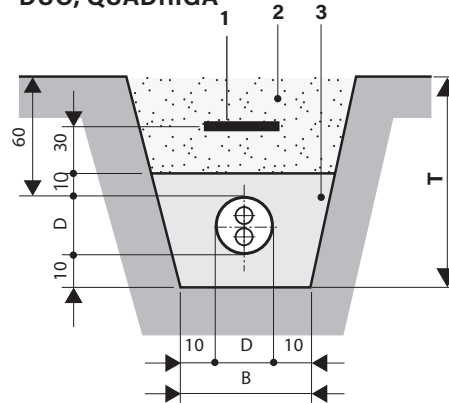

Figures in cm

Casing pipe Ø D mm	Width B cm	Depth T cm
78	45	80
93	50	80
113	55	85
128	55	85
143	60	85
163	65	90
183	70	95
202	75	95
250	80	100

Casing pipe Ø D mm	Width B cm	Depth T cm
93	30	80
113	30	85
128	35	85
143	35	85
163	35	90
183	38	95
202	40	95

Trench profile, 4 CALPEX pipes

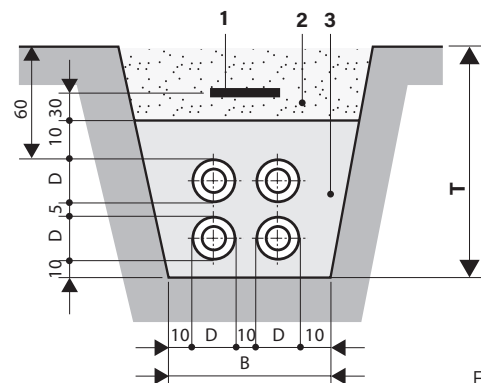
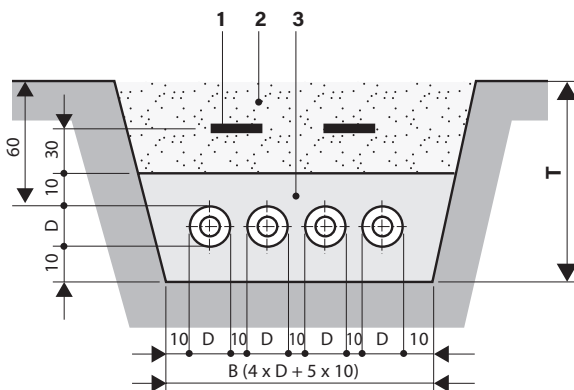

Figures in cm

- 1 Pipe warning tape; see sheet CPX 1.430
- 2 Excavated material
- 3 Fill material see below

Installation depth:
 Max. installation depth: 2.6 m
 Our approval is required for installation at greater depths.

The fill material in the embedment must comply with EN 13941-2 and satisfy the following minimum requirements:

- Friable, round-edged sand-gravel mixture
- Permissible grain size: 0...8 mm
- Coefficient of uniformity according to DIN EN ISO 14688-2 larger than 1.8

SLW 30 $\hat{=}$ 300 kN total load as per DIN 1072; if subject to higher traffic loads (e.g. SLW 60), a load-distributing superstructure as per RStO75 is required.

With no traffic load, the minimum trench depth **T** can be reduced by 20 cm.

- Maximum 10 percent by mass \leq 0.075 mm
- Maximum 3 percent by mass \leq 0.02 mm
- Proctor density min. 94%; optimal 97 up to 98%

Pipe warning tape

CALPEX pipe warning tape

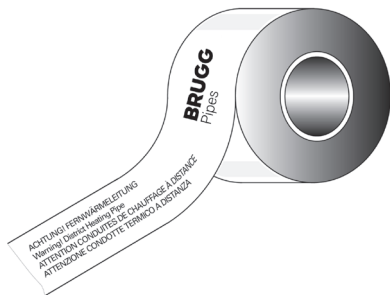

Pipe warning tape to be laid in the ground.
Roll length: 250 m

CALPEX trench structure

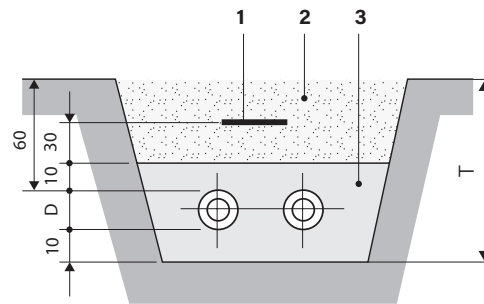

- 1 Pipe warning tape
- 2 Excavated material
- 3 Washed sand

Installation depth; see sheet CPX 1.505

Laying tools

Using the CALPEX unwinding device and the CALPEX – power winch makes it possible to easily and quickly unroll and lay the flexible composite pipe systems.

CALPEX-Unwinding device



Dimension: \varnothing 400 x 157 cm
Load capacity: 1'000 kg

Power winch



Our recommendation:
<https://www.portablewinch.com>

CALPEX-Squeezing device

for temporary closing up PE- and PEX-pipes

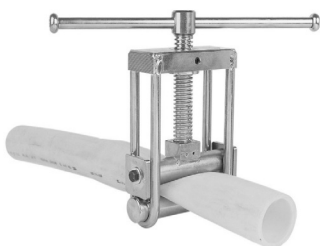

Squeezing device \varnothing 32 – 63 mm (SDR11)



Squeezing device \varnothing 75 - 160 mm (SDR11)

Connection (rigid/flexible)

CALPEX to insulated steel pipes

Installation instructions for transition from CALPEX to insulated steel pipe (KMR)

1. Connection to T-piece (ΔI small)

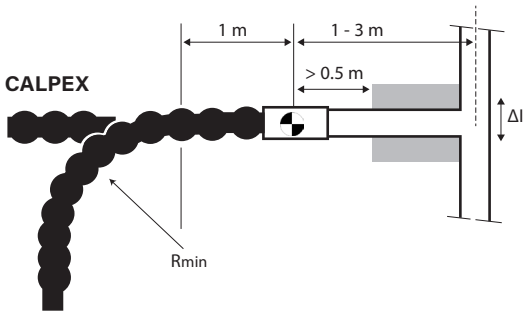

2. Connection to T-piece (ΔI large)

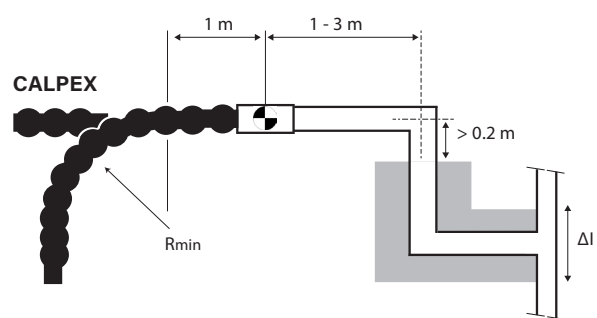

3. Connection to L-bend (ΔI small)

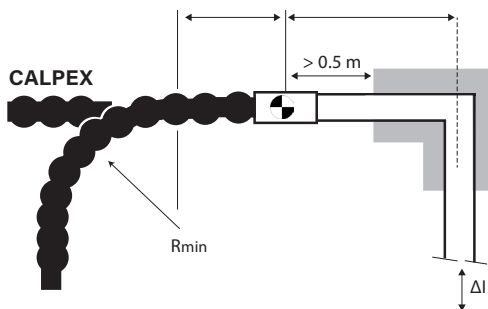

4. Connection to L-bend (ΔI large)

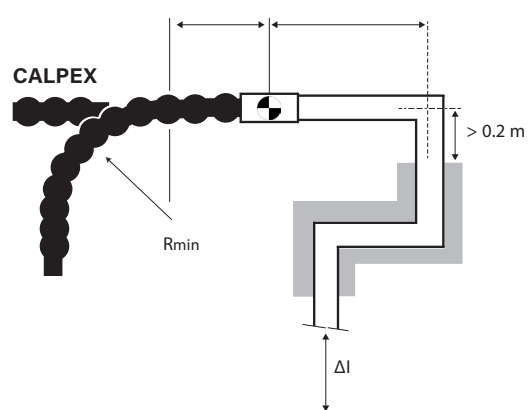

5. Connection to Z-bend

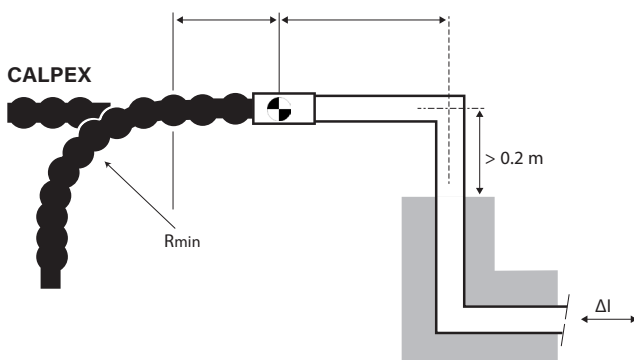

Comments:

1. Thermal elongation ΔI of the KMR system that is transferred to the centre of the connector  must be less than: axial 3 mm
2. Grey = expansion pad for the KMR system, designed in line with the state of the art

House entry, screwed connector/ compression joint

Shaft entry

Connection with external thread

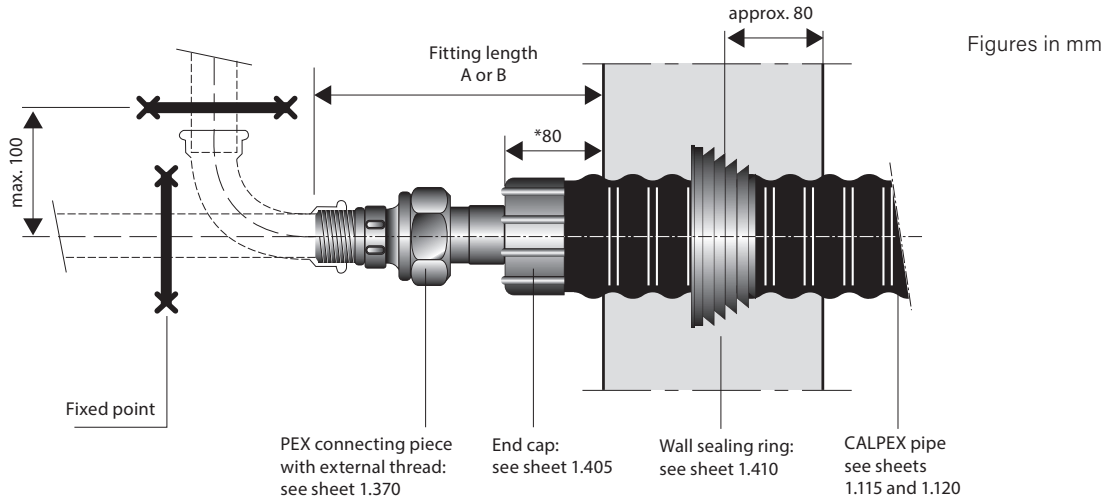

Screwed connector



Type A



Type B

Compression joint



Type A



Type B

CALPEX PUR-KING

Heating, 6 bar PEX-Pipe mm	Fitting lengths	
	A mm	B mm
25 x 2.3	190	190
32 x 2.9	195	190
40 x 3.7	200	200
50 x 4.6	205	210
63 x 5.8	225	215
75 x 6.8	230	225
90 x 8.2	245	235
110 x 10.0	260	240
125 x 11.4	270	250
140 x 12.7	270	250
160 x 14.6	270	270

CALPEX SANITARY, 10 bar

20 x 2.8	190	190
25 x 3.5	190	190
32 x 4.4	195	200
40 x 5.5	205	210
50 x 6.9	205	210
63 x 8.7	220	215
75 x 10.3	230	225
90 x 12.3	240	235
110 x 15.1	260	240
125 x 17.5	260	250

CALPEX PUR-KING

Heating, 6 bar PEX-Pipe mm	Fitting lengths	
	A mm	B mm
25 x 2.3	260	250
32 x 2.9	260	250
40 x 3.7	270	260
50 x 4.6	270	270
63 x 5.8	320	310
75 x 6.8	320	310
90 x 8.2	330	310
110 x 10.0	340	310
125 x 11.4	340	310
160 x 14.6	340	340

CALPEX SANITARY, 10 bar

20 x 2.8	260
25 x 3.5	260
32 x 4.4	260
40 x 5.5	270
50 x 6.9	270
63 x 8.7	320

House entry, compression joint

Fixed point forces

Connection with external thread

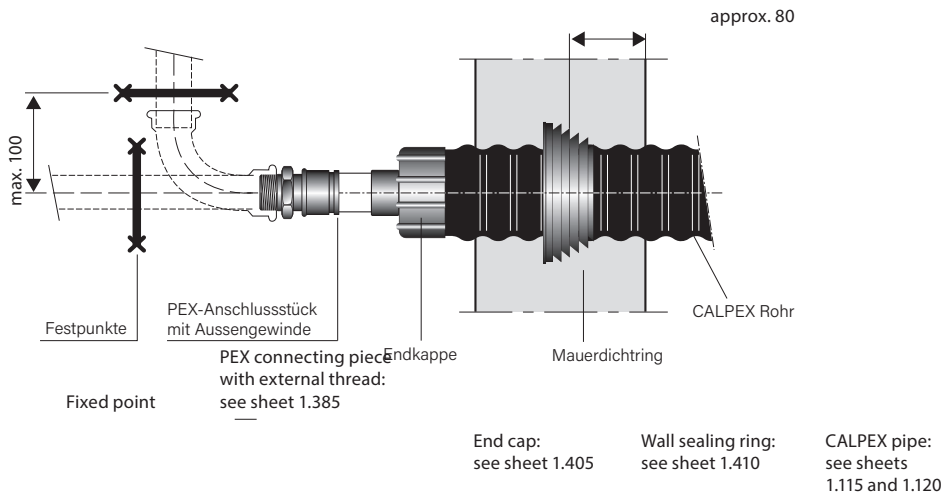

Fixed point forces occurring

CALPEX PUR-KING (Heating, 6 bar)

Maximum fixed point forces occurring per pipe for:

Type	Type	TB = 60 °C, pB = 6 bar	
		Fmax [N]	Fmax [N]
25/ 76	25/ 91 PLUS	640	924
32/ 76	32/ 91 PLUS	1036	1493
40/ 91	40/111 PLUS	1639	2367
50/111	50/126 PLUS	2553	3686
63/126	63/142 PLUS	4013	5782
75/142	75/162 PLUS	5693	8205
90/162	90/182 PLUS	8228	11864
110/182	110/202 PLUS	12260	17675
125/182	125/202 PLUS	15872	22888
140/202		19928	28747
160/250		26004	37502

CALPEX SANITARY (Sanitary, 10 bar)

Maximum fixed point forces occurring per pipe for:

TB = 60 °C, pB = 10 bar		
Type	DN	Fmax [N]
20/ 76	16	820
25/ 76	20	1350
32/ 76	25	1730
40/ 91	32	2700
50/111	40	4230
63/126	50	6715

Fixed points

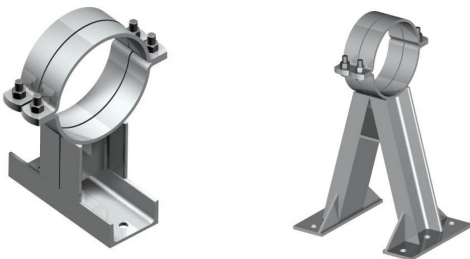

Installation of house entry



1 Mark the distance (x, y, z) + 1 cm from the end of the pipe.



2 Cut the casing pipe with saw.



3 Split the casing pipe with knife.
Note: Don't damage the carrier pipe!



4 Peel off the casing.



5 Cut back/remove the insulation along length (X, Y, Z).
Note: Don't damage the carrier pipe!



6 Install the wall sealing ring.

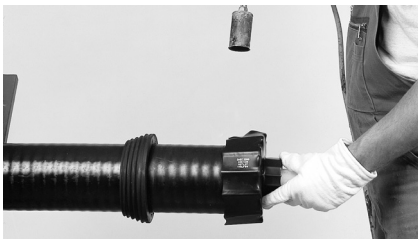

7 Carefully shrink on the pipe end closure according to the Raychem DHEC installation instruction.



8 Install the fitting as per the enclosed installation instructions.

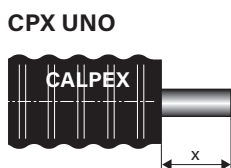

CPX UNO
UNO screwed connector
House connection:
ø 20 - 75: X = **90 mm**
ø 90 - 110: X = **110 mm**

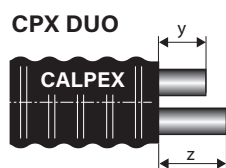

CPX DUO
DUO screwed connector
House connection:
ø 20 - 75: Y = **80 mm**
ø 20 - 75: Z = **180 mm**

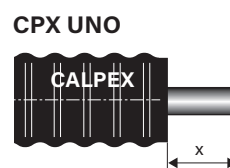

CPX UNO
UNO compression joint
House connection:
ø 20 - 50: X = **140 mm**
ø 63 - 125: X = **180 mm**
Joint/sleeve:
ø 20 - 50: X = **110 mm**
ø 63 - 110: X = **140 mm**
ø 125 - 160: X = **150 mm**

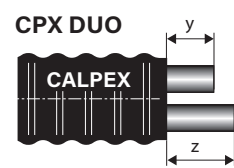

CPX DUO
DUO compression joint
House connection:
ø 20 - 50: Y,Z = **140 mm**
ø 63 - 75: Y,Z = **160 mm**
Joint/sleeve:
ø 20 - 50: Y,Z = **110 mm**
ø 63 - 75: Y,Z = **140 mm**

Note: Install the CPX-Clip-Shells according to the installation instruction!

Installation tools

general and for screwed connector

Cut to length and strip insulation

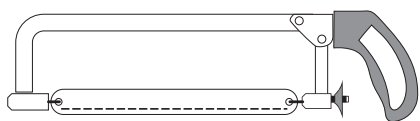

The saw is used to cut the casing pipe and the insulation

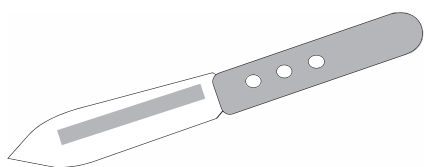

Knife to split casing and remove insulation

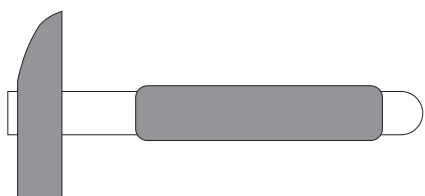

Hammer as auxiliary tool

Fit of connection piece

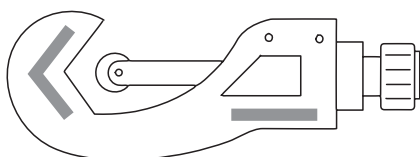

Pipe cutter for PEX pipe

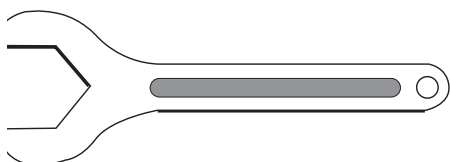

Spanner wrench

Shrink procedure

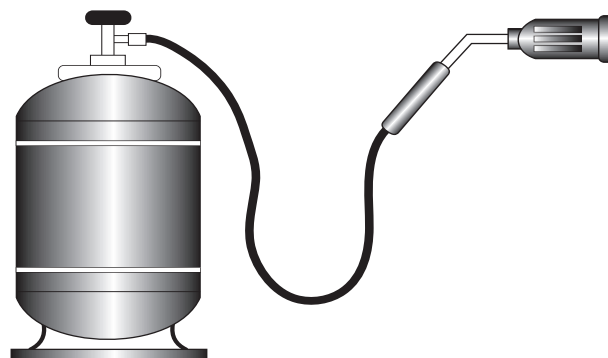

The gas burner is used to shrink hoses and joints



It is recommended that gloves are worn for shrinking work.

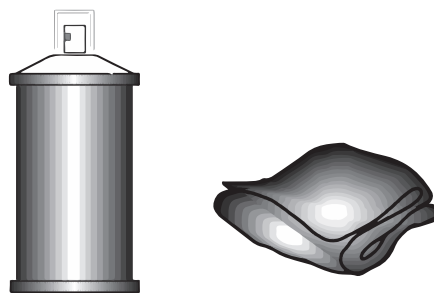

Cleaning products and cleaning cloths

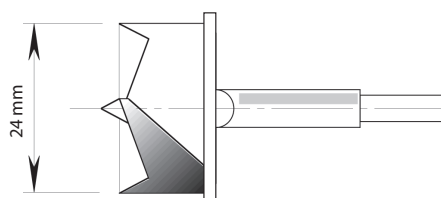

Flat bit for cutting filler hole

Installation tools

for press fit joints

Manual tool for PEX Ø 22 - 40 mm (packed in one case)

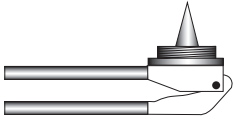

Expander tool, up to Ø 32 mm (basic tool)

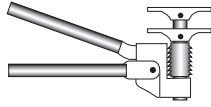

Press tool, up to Ø 40 mm
Expander tool for Ø 40 mm (basic tool)



Case with basic tool including head and yoke

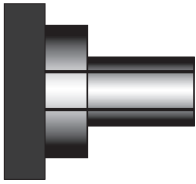

Expander head, up to Ø 32 mm

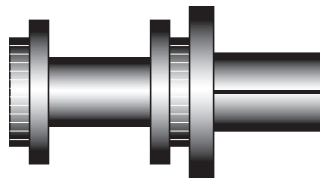

Expander head, over Ø 40 mm

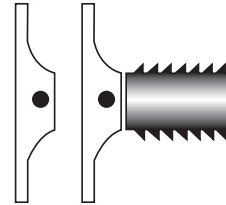

Press yoke, Ø 22 - 40 mm

Hydraulic tool for PEX Ø 50 - 110 mm (packed in two cases)

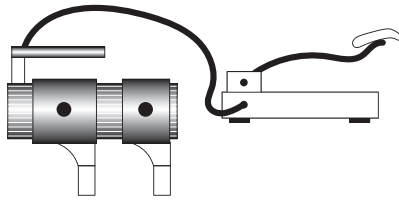

Hydraulic press and expander tool
Ø 50 - 110 mm including foot pump (basic tool)

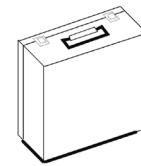

Case with basic tool (without heads and yoke)

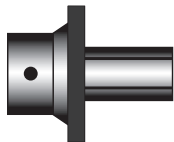

Expander head
Ø 50 - 110 mm

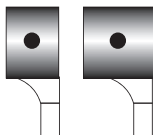

Press yoke
Ø 50, 63 mm

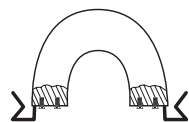

Reducer Ø 75/90 mm
for yoke, Ø 110 mm

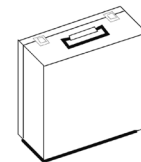

Case with expander heads and press yoke

Electro-hydraulic tool for PEX Ø 125 - 160 mm (packed in two cases)

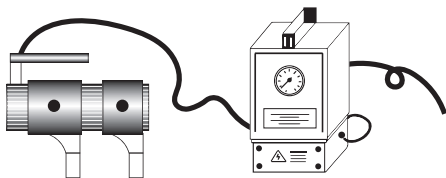

Hydraulic press and expander tool
Ø 125 - 160 mm including foot pump (basic tool)

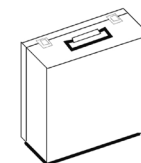

Case with basic tool (without heads and yoke)

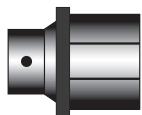

Expander head
Ø 125 - 160 mm

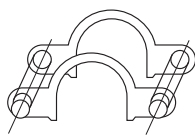

Press yoke
Ø 140 mm, 160 mm

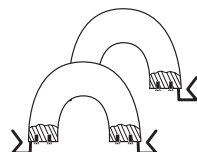

Reducer Ø 125 mm
for yoke, Ø 160 mm

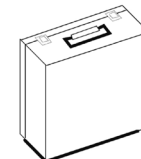

Case with expander heads and press yoke

Heating strip, CALPEX SANITARY (Sanitary, 10 bar)

Drawing in, sensor, joint

1. Pulling through the heating strip

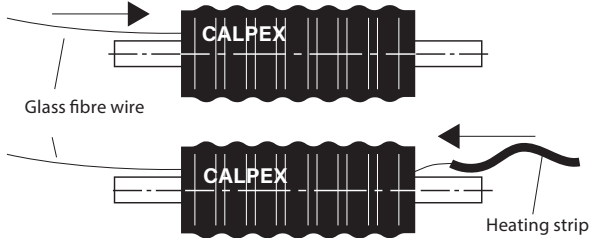

1. Unroll the pipe so that it is straight, next to the trench (without bends). See also CPX 1.120. Shorten the casing and cut back the channel. From one end, push the glass fibre wire (ø 6.5 mm) through the channel. The heating strip can be pushed in for straight lengths of up to 30 m.

2. Connect the heating strip or pull cord to the wire (drill a hole in the strip) and pull through the heating strip.

2. Installation of the temperature sensor for frost protection

The temperature sensor has to be installed on the carrier pipe, opposite the heating strip. It must be installed at the coldest point of the pipe (outside the building). For this purpose, cut open an area of the casing measuring 10 x 7 cm and peel it off, cut open 10 x 7 cm of foam, fix the temperature sensor onto the carrier pipe with adhesive tape, fill the hole with the insulation material supplied, apply filling adhesive S1113 below and above the temperature sensor cable (see Detail B), and seal with the sealing set.

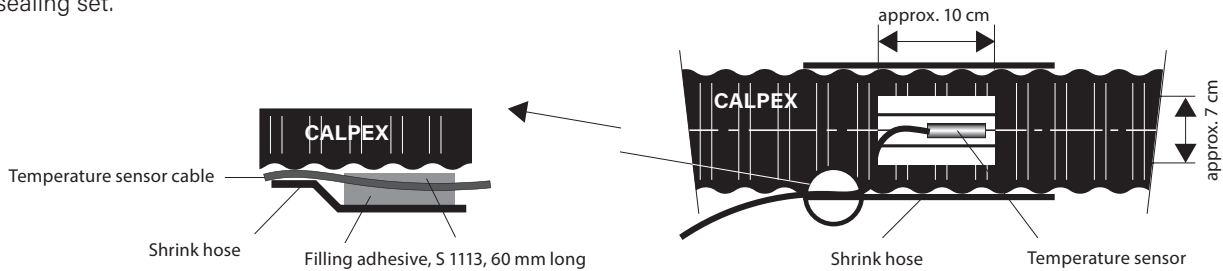

3. Remove the insulation

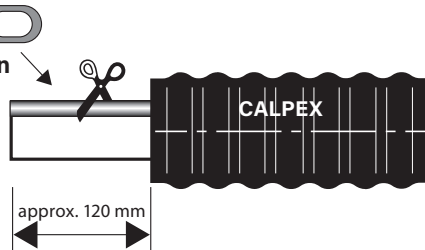

Shorten the casing by 120 mm and cut off the exposed channel.

4. Joint

Through connection $L \leq L_{max}^*$
Feed in from one end

Separate of heating strips $L > L_{max}^*$
Feed in from both end (each strip $\leq L_{max}$)

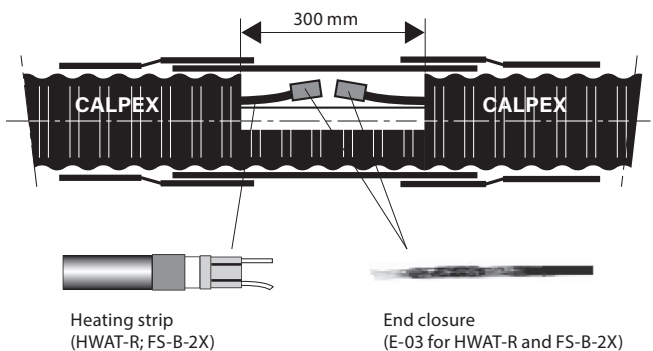
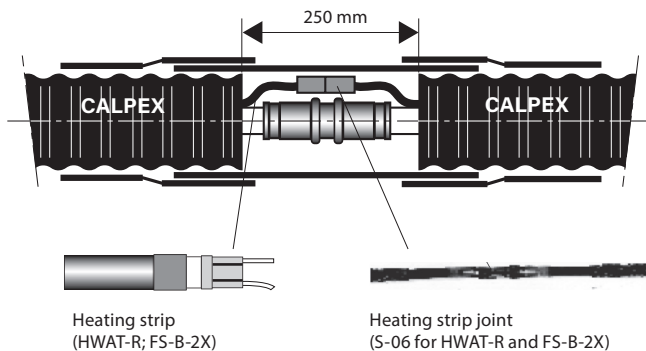

Protect the heating strip against moisture
* L_{max} = max. permitted length for heating strip

Expose and cut off the heating tape duct over a length of 300 mm. Install the end end, fit the damping material, seal with the «Through-through» socket set.

The heating strip and the accessories are supplied and installed by the electrician!