



# Biogas technology

## Efficient heating of biogas plants

The BIOFLEX fermenter heater

**BRUGG**  
Pipes

Pioneers in Infrastructure



## The system package for heating fermentation tanks

### System advantages

- surface up to 50 % higher maximum heat transfer through optimized wall thickness
- pipe profile with optimized thermal and hydrodynamic characteristics
- great flexibility; easily deformable, small bending radii
- can be laid in long lengths
- highly economical with corrosion-resistant materials
- prevention of calcification through turbulent water flow
- quality assurance through helium testing
- “endless manufacture”
- high mechanical load capacity

### BIOFLEX corrugated piping

BIOFLEX is a single-walled corrugated piping system made of stainless steel. The key constructional element of these pipes manufactured at our works in long lengths is the helically corrugated pipe.

### Connector technology

Optimized connections and fittings enable the pipes to be coupled to all standard connections. A flameless graphite packing technology (GRAPA) is used here. This easy-to-fit connector system enables time-savings on installation work without welding.

### Maximum heat exchange without calcification

Vortices are formed in the helically corrugated pipe. These keep the water in a constant state of turbulence and exchange. The core current is heterodyned by a swirl component formed by the pipe geometry, which creates additional vortices. On the one hand this generates maximum heat exchange while on the other it prevents calcification.

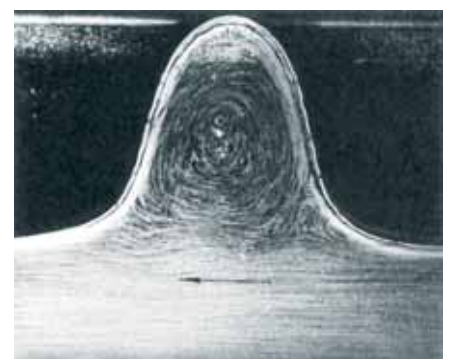



### Fermenter equipment with BIOFLEX corrugated piping

The helically corrugated **BIOFLEX** piping is the ideal solution through its simple and non-weld installation.

Other advantages:

- excellent corrosion resistance
- highly flexible and self-compensating
- far higher heat transfer than with conventional piping

### Non-weld installation in record time

- fast and convenient laying
- simple pipe securing
- non-weld connectors including through-connection through the tank wall

For installation instructions and technical data: see worksheets Biogas technology BGT.

### System components for the generation and use of regenerative energy

- 1 BIOFLEX corrugated piping
- 2 CALPEX heat-insulated pipe
- 3 PREMANT plastic-sheathed piping and CASAFLEX district heating pipe

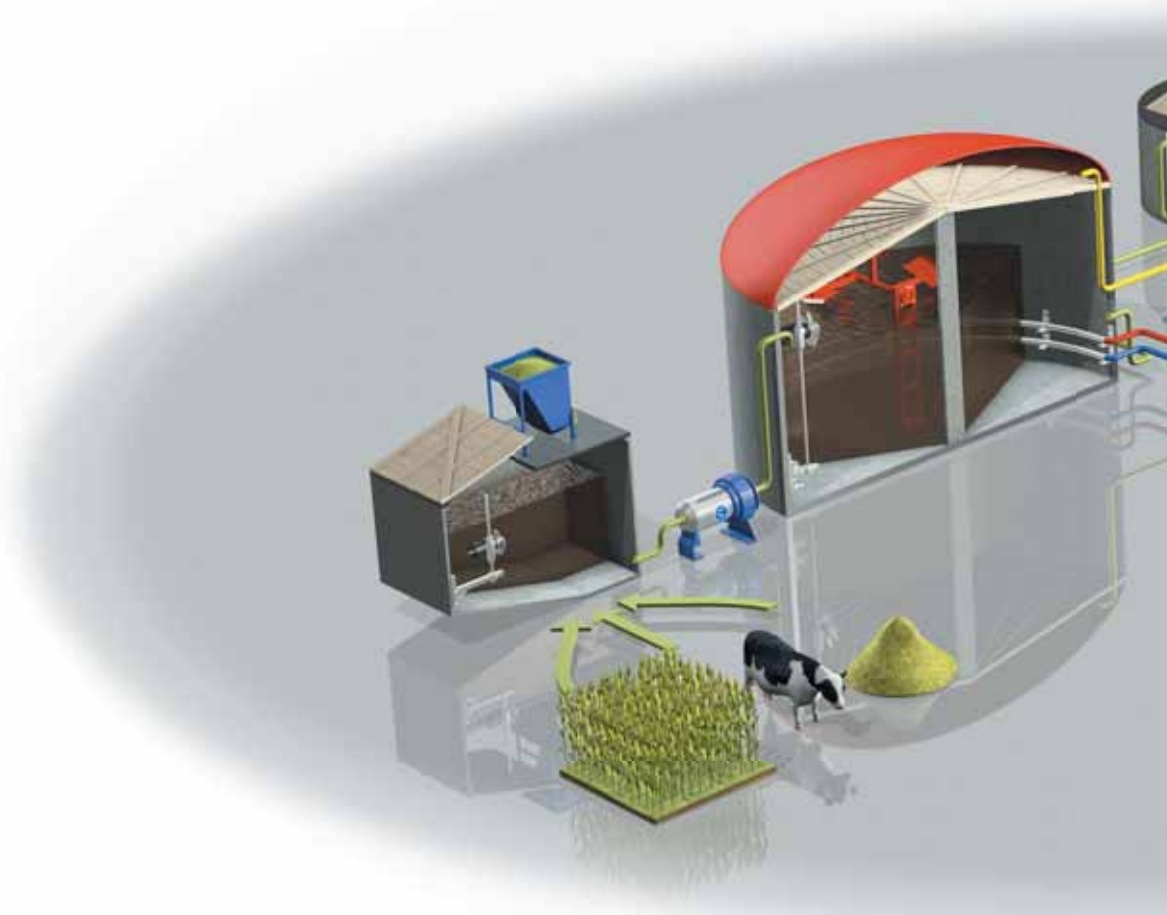



### Extensive district heating networks

**PREMANT** plastic-sheathed piping is specially designed as a mains pipe for large-scale district heating networks. The properties: high insulation coefficient and leak detection systems.

Dimensions: DN 20 – DN 1000

**CASAFLEX** was specially designed for high-temperature applications. Its flexible metallic stainless steel medium pipe allows it to transport media with a temperature of up to 160° C.

Dimensions: DN 20 – DN 100

### CALPEX heat-insulated pipe

**CALPEX** can be laid direct into the trench with a minimum of work. Connections in the ground can largely be dispensed with. Due to its pre-insulation, the pipe has a high insulation coefficient. The advantage: energy loss is kept to a minimum.

The desired length is delivered on site in one piece in a coil.

Grouted or screwed connectors.

Dimensions: DN 20 – DN 150



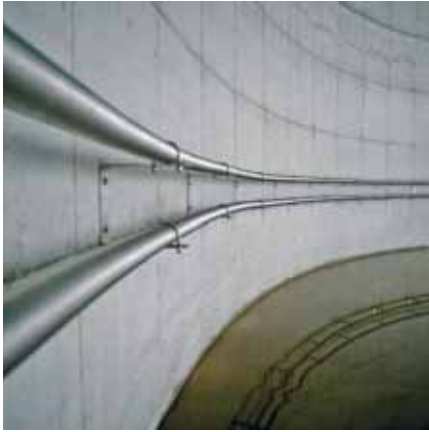

## Pipe laying – connector technology

### System package

#### BRUGG fermenter heating

In order to ensure optimal heat transfer to the substratum, the BIOFLEX CNW 60/66 (DN 50) corrugated pipe is fixed to the wall of the fermentation tank in one or more heating coils.

In addition to the corrugated pipe CNW 60/66, the system package also includes the GRAPA connector system, the necessary wall through-connections including seals and the special brackets for securing the piping to the fermenter wall.

There are two different options for connecting the corrugated pipes to the hot water mains:

### Connection inside the fermenter

With the connection inside the tank the corrugated pipe is connected to a rigid pipe by means of the flameless GRAPA graphite connector system. This is then led out of the fermenter through the fermenter wall.

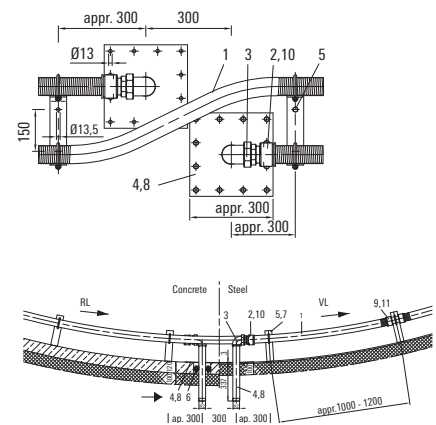

### Connection outside the fermenter

In this variant, in order to set up the connection with the corrugated pipe using the flameless GRAPA graphite connector system outside the fermenter, the corrugated pipe is bent through a small bending radius and led through a pipe sleeve which passes through the fermenter wall. This does away with the need for a joint in the fermenter.

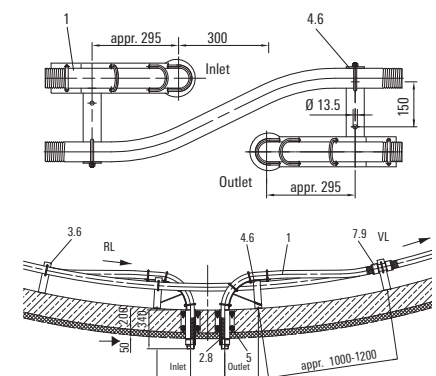



- Legend**
- Partner
  - ▲ Production sites
  - Branches



# BRUGG

Pipes

BRUGG Rohrssystem AG · Industriestrasse 39 · 5314 Kleindöttingen · Switzerland · [bruggpipes.com](http://bruggpipes.com)  
BRUGG Rohrssysteme GmbH · Adolf-Oesterheld-Straße 31 · 31515 Wunstorf · Germany · [bruggpipes.com](http://bruggpipes.com)